



Berkeley Nucleonics Corporation

Product Comparison
Internal Document

Berkeley Nucleonics

60 Years Supplying RF and MW T&M Instruments

Founded in 1963 in Berkeley, California





Represented in more than 40 countries

Profitable for > 60 consecutive years



BNC RF & Microwave Products



SINGLE-CHANNEL RF / MW SIGNAL GENERATORS	MULTI-CHANNEL RF / MW SIGNAL GENERATORS	FREQUENCY SYNTHESIZERS SINGLE- / MULTI-CHANNELS	SIGNAL SOURCE ANALYZER / PHASE NOISE TESTERS
			
<p>835/845: single-channel RF/MW SGs up to 4, 6, 12, 20, 26 GHz, analog modulations</p> <p>865B: high-performance MW SGs up to 12, 20, 26, 40 GHz, analog modulations</p> <p>870A: high-purity MW SGs up to 12, 20, 40, 54 GHz, analog modulations</p> <p>875: ultra-agile, vector RF and MW SG up to 4, 6, 12, 20, 40 GHz, digital modulations</p>	<p>865B: up to 4 fully independently adjustable, phase-coherent and phase memory, up to 6, 12, 20, 33, 40 GHz</p> <p>870A Rackmount: up to 4 fully independently adjustable, phase-coherent, up to 12, 20, 40, 54 GHz</p> <p>875 Rackmount: up to 4 fully independently adjustable, phase-coherent, 4, 6, 12, 20, 40 GHz</p>	<p>845-M / 865B-M: single- and multi-channel frequency synthesizers up to 20, 40 GHz</p> <p>825-M: up to 20 GHz, 1/2/3/4 channels, phase-coherent</p> <p>805-M / 866-M: up to 22 / 40 GHz, multi-channel configurable</p> <p>805-SG: NI QuickSyn FSW-0020 replacement and upgrade</p>	<p>7000 Series: versatile, broadband instruments up to 7, 26, 40, 50 GHz with multiple measurement modes and high measurement sensitivity</p>

Single-Channel RF & MW Signal Generators

Universities & Research

Communications

Satellite Communication

Defense

Microwave



Model 835/845 Series

Single-Channel RF/MW SGs – Basic Models



The Model 835/845 consists of a series of very compact, portable analog signal generators covering frequency up to 4 / 6 / 12 / 20 and 26 GHz. Fast switching, low noise.



MODELS	DESCRIPTION	OUTPUT POWER
835-4	9 kHz to 4 GHz	-120 to +18 dBm
835-6	9 kHz to 6 GHz	-120 to +18 dBm
845-6	9 kHz to 6 GHz	-120 to +25 dBm
845-12	9 kHz to 12 GHz	-120 to +25 dBm
845-20	9 kHz to 20 GHz	-120 to +25 dBm
845-26	9 kHz to 26 GHz	-120 to +25 dBm

Features:

- Modulation: AM, FM, PM, PULSE
- Benchtop

Model 865B

Single-Channel RF/MW SGs – High Performance Models



The 865B series consists of a series of very compact, portable analog signal generators covering up to 12.75, 20, 26 and 40 GHz. Very low phase noise, excellent signal purity, fast switching, high output power, en



MODELS	DESCRIPTION	OUTPUT POWER
865B-12	8 kHz to 12.75 GHz	-120 to +24 dBm
865B-20	8 kHz to 20 GHz	-120 to +24 dBm
865B-26	8 kHz to 26 GHz	-120 to +24 dBm
865B-40	8 kHz to 40 GHz	-120 to +24 dBm

Features:

- Excellent signal purity: ultra-low phase noise and low spurious
- Combination of highest output power and fast switching
- Analog modulation FM, PM, AM, PULSE, PULSED CHIRPS
- Powerful touch-display control
- Portable, power bank operational



Model

835

845

865B Series

Options

(Subject to Change)

OPTIONS	DESCRIPTION
Option HP	High output power
Option OPE3/PE/PE2	Mechanical step attenuator
Option PE4	Electrical / mechanical step attenuator
Option LN/LN+	Enhanced close in phase noise
Option FS	Fast switching
Option NM	Remove modulation functions
Option MOD	AM, FM, PM, PULSE
Option FILT	Enhanced harmonic rejection
Option AVIO	Avionics modulations
Option VREF	Variable external reference
Option REAR	Move output to rear panel
Option 1URM	1U 19" Rackmount unit
Option B3*	Internal battery module
Option 8K	Frequency extension to 8 kHz
Option GPIB	Adding GPIB interface

Model 870A

Single-Channel MW SGs – High-Purity Models



The Model 870A consists of a series of very compact, portable analog signal generators covering up to 12.75, 20, 40, and 54 GHz. Extremely low phase noise, excellent signal purity.



MODELS	DESCRIPTION	OUTPUT POWER
870A-12	9 kHz to 12.75 GHz	-120 to +20 dBm
870A-20	9 kHz to 20 GHz	-120 to +20 dBm
870A-40	9 kHz to 40 GHz	-120 to +20 dBm
870A-50	9 kHz to 54 GHz	-120 to +20 dBm

Features:

- Phase noise: -130 dBc/Hz, @ 20 kHz from 10 GHz
- Harmonics: -50 dBc; Spurious: -85 dBc (X band)
- Fast Switching 5 μ s with option FS
- Refs: 10/100 MHz; CLK: 6 GHz
- Int./Ext. Pulse Mod; Int. AM/FM/PM

Model 870A

Phase Noise and Max Power

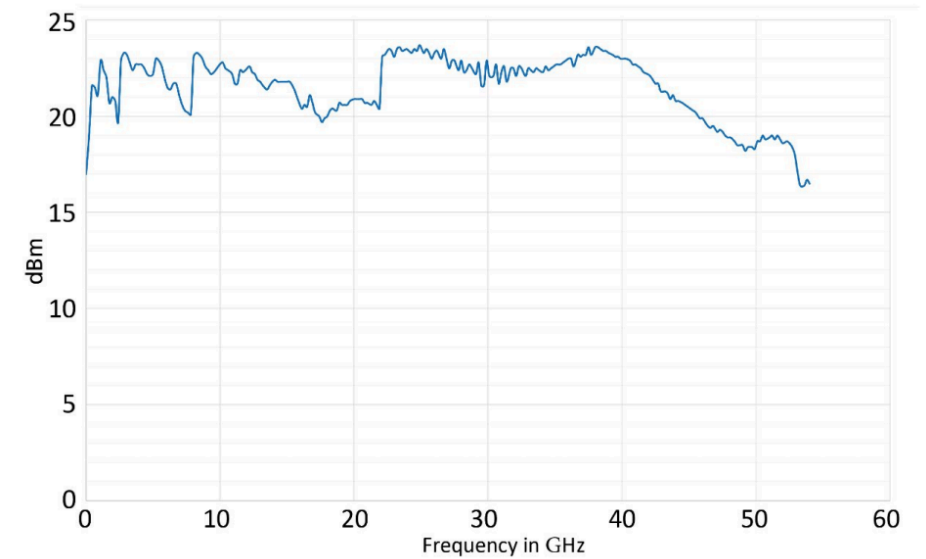
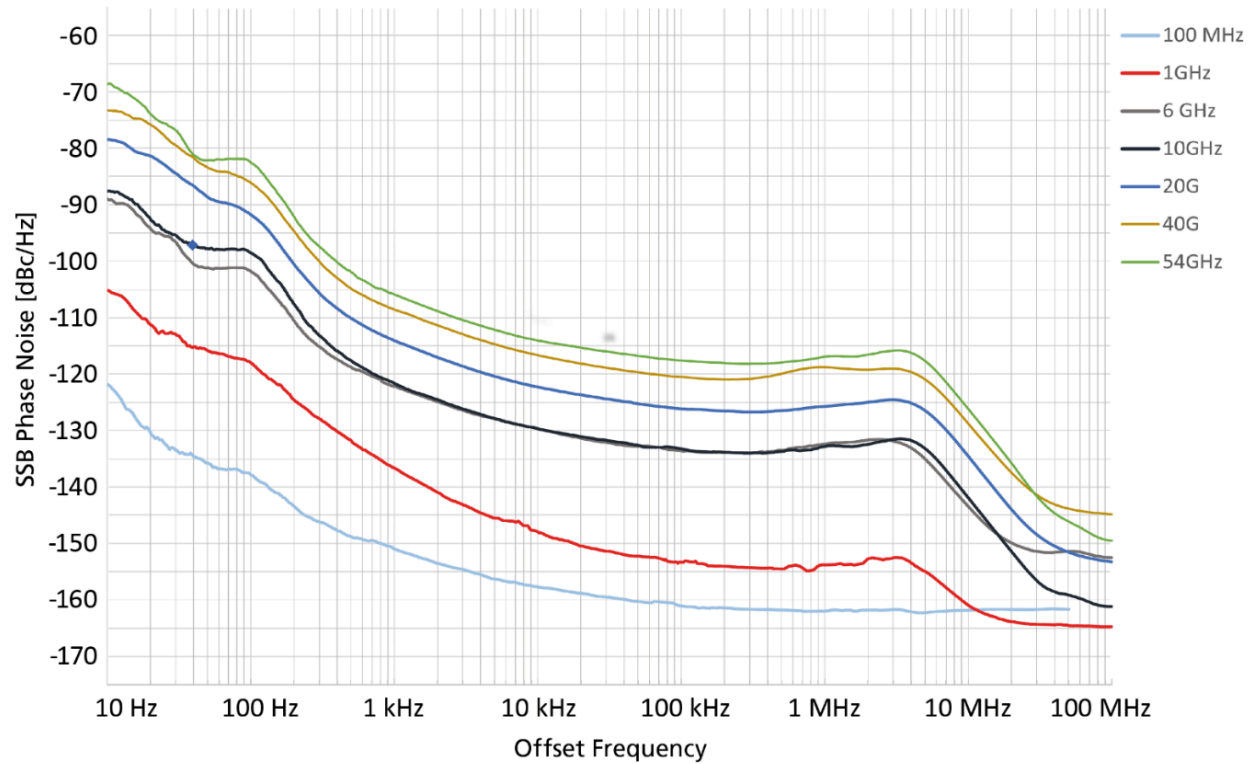

Model 870A

Harmonics and Non-Harmonics

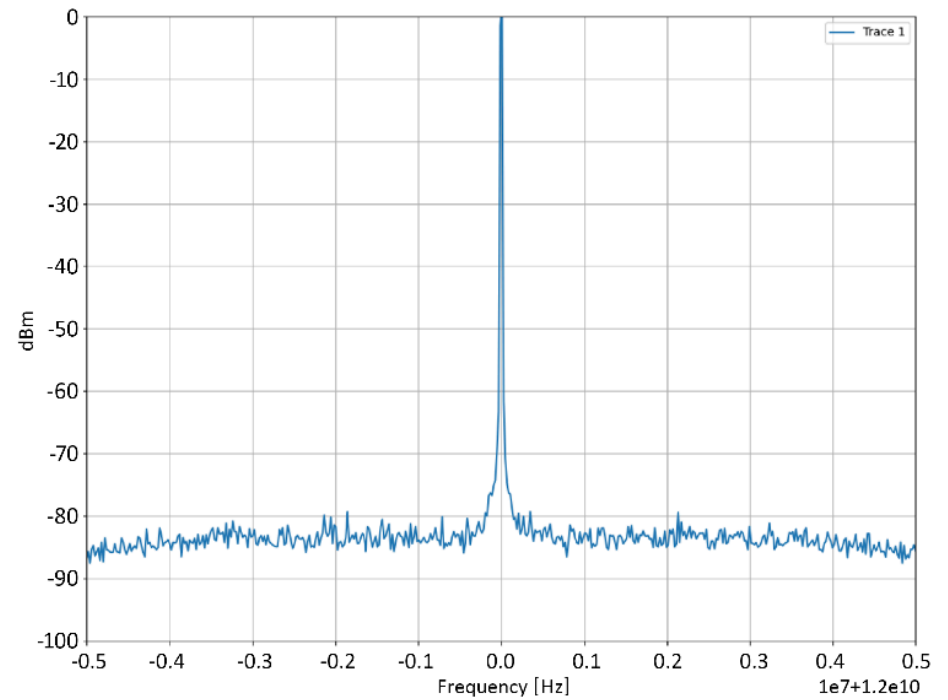
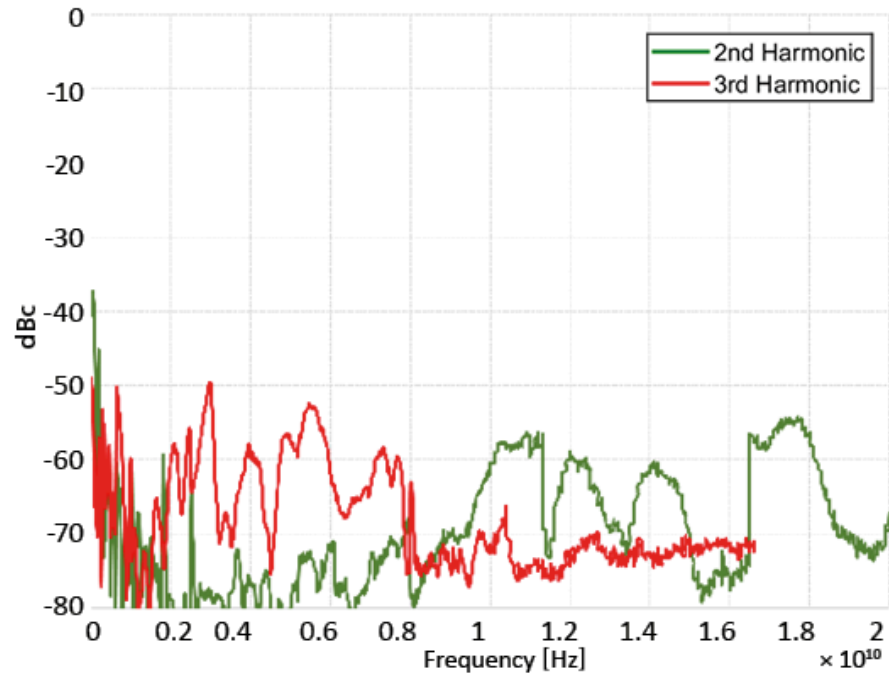

Model 870A

Pulse Modulation

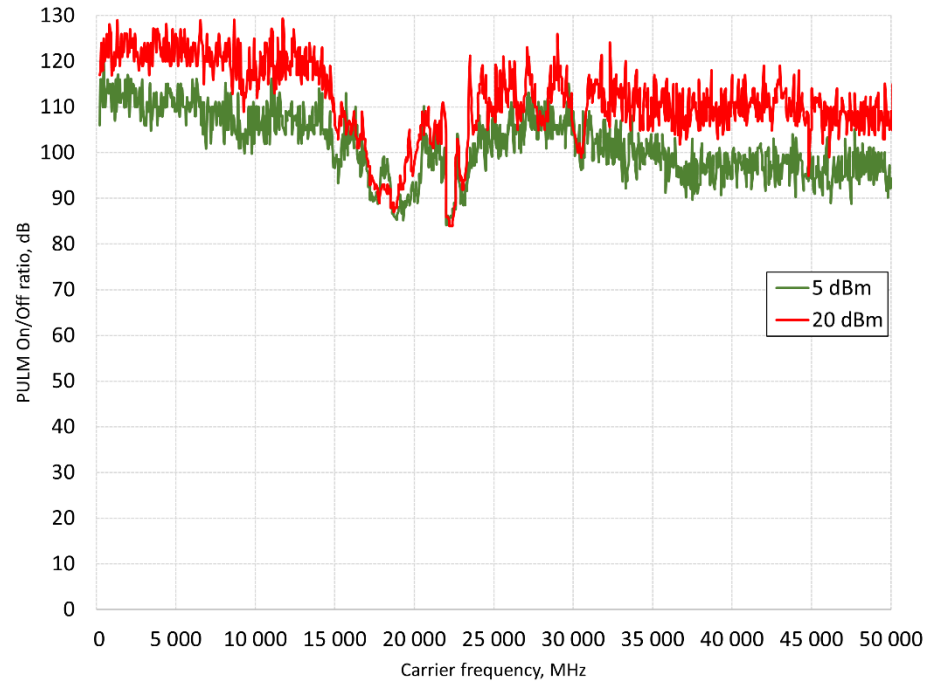

20 ns Pulse Width

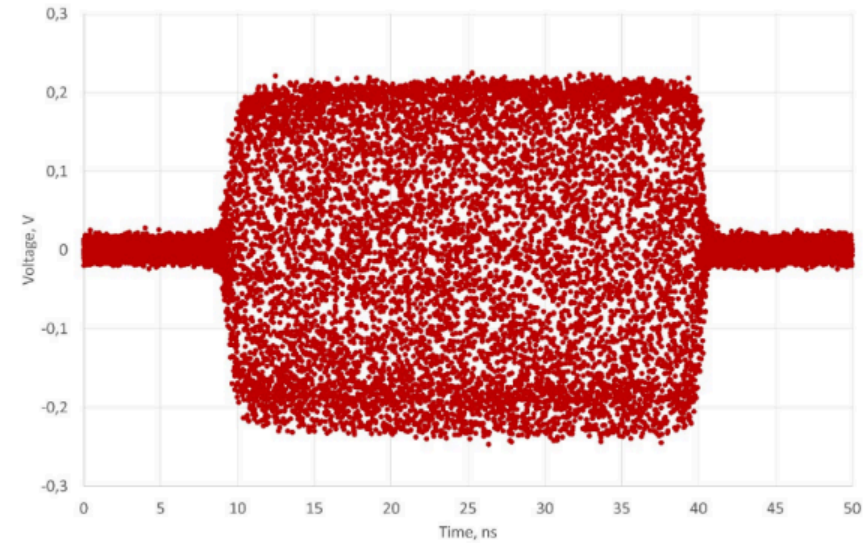

50 GHz, 30 ns Pulse
Rise/Fall time: 2-3 ns

Popular Microwave Signal Generators

and BNC Alternatives



Keyword	Avg. Monthly Searches on Google	Company	BNC Alternative
SMA100B	170	R&S	870A, exception High power applications
SMB100A	170	R&S	845, 865B, or 870A
SMB100B	90	R&S	845-6

Model 875 Series

Single-Channel RF/MW VSGs – Ultra-Agile



Wideband I/Q modulation, ultra-agile switching / sweeping / chirping.
Internal AWG. I/Q data playback, fast control port, ...



MODELS	DESCRIPTION	OUTPUT POWER
875-4	10 MHz to 4 GHz	-120 to +17 dBm
875-6	10 MHz to 6 GHz	-120 to +15 dBm
875-12	10 MHz to 12 GHz ¹	-120 to +15 dBm
875-20	10 MHz to 20 GHz	-120 to +19 dBm
875-40	10 MHz to 40 GHz	-120 to +14 dBm

Features:

- Ultra-fast switching: <math>< 100 \text{ ns}</math> within mod BW; 2 μs wide-band
- Low phase noise: -145 dBc/Hz at 1 GHz, 20 kHz offset
- 400 MHz digital and 100 MHz analog modulation bandwidth (-115 dBc/Hz at 40 GHz, 20 kHz offset)
- Internal baseband SG: 500 MHz sampling, 512 MSa memory

Model 875

Function Diagram

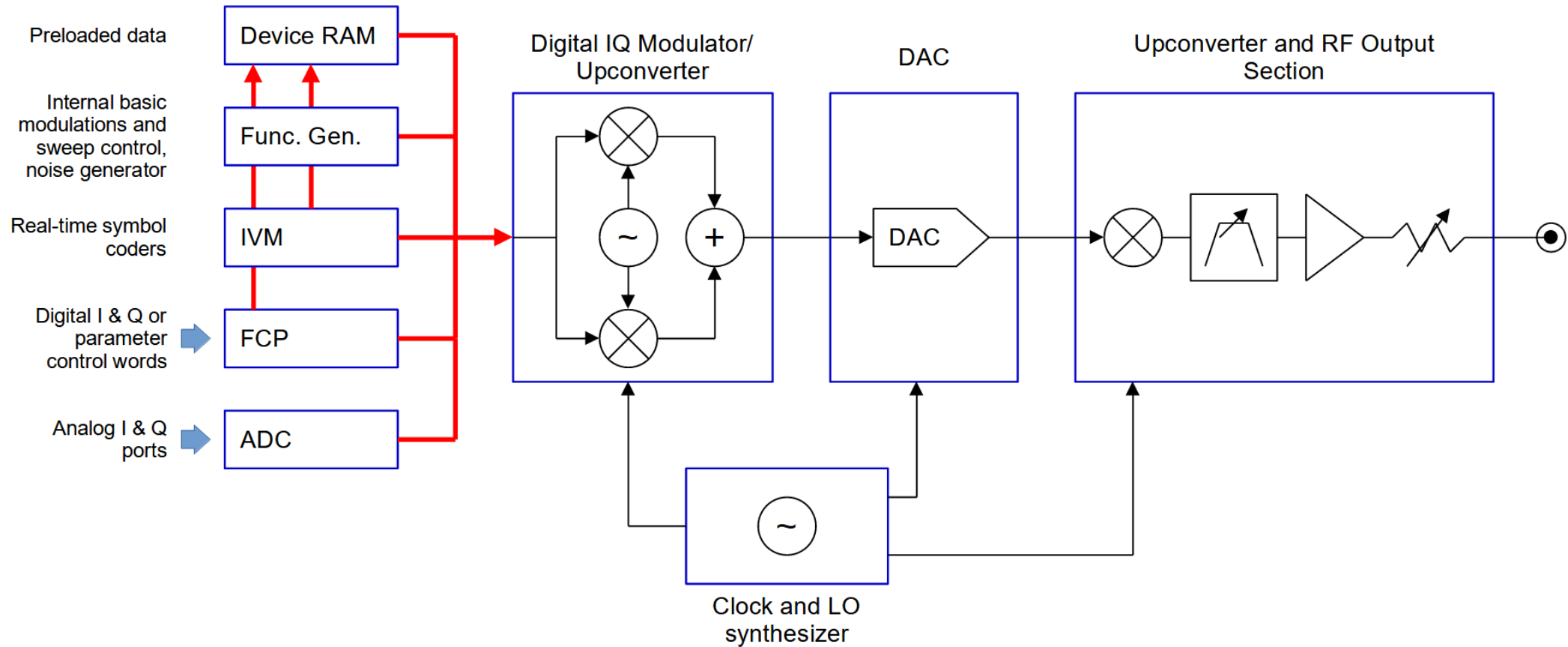

Model 875

Digital Modulation

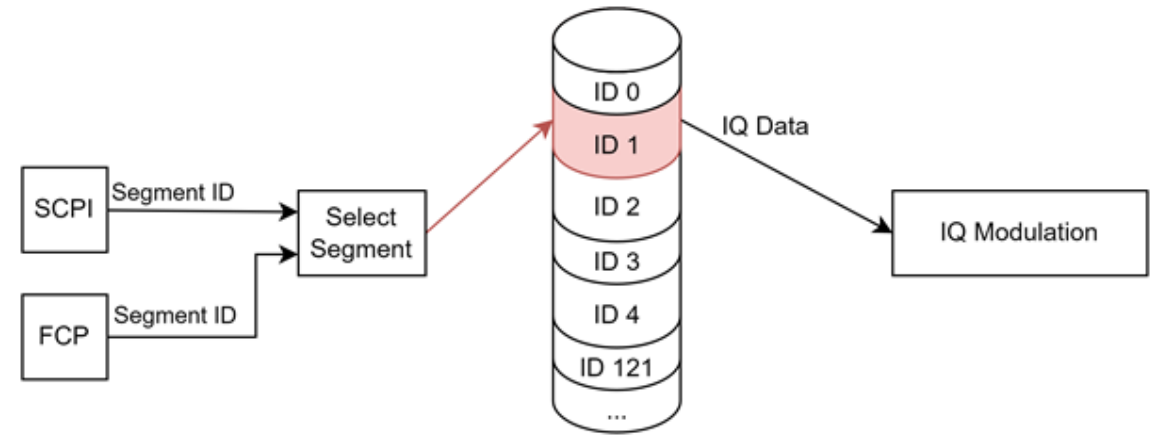

- **Sampling rate:** adjustable up to 500 MHz
Modulation bandwidth: 400 MHz
- **Internal I/Q data storage size:** 512 MSa (16 bits I and 16 bits Q) up to 4 marker bits
- Customer compiled I/Q data uploadable via GUI SW and SCPI command
- **Playback from internal I/Q storage:** sequential or segment address controlled; internally programmable
or addressing through FCP
- Fast settling and low latency

Multi-Channel RF & MW Signal Generators

Radar

Quantum Computing

Automated Testing

Aerospace & Defense



Model 855B Series

Multi-Channel RF & MW Analog SGs



The 855B multi-channel SG family consists of various models supporting up to 6 / 12 / 20 / 33 / 40 GHz. The multiple outputs are phase-coherent, fast switching, and exhibit very low phase noise. All the channels are independently adjustable. Optionally, they also have features of phase-coherent switching and phase memory.



MODELS	DESCRIPTION	OUTPUT POWER
855B-6	300 kHz to 6 GHz	-80 to +25 dBm
855B-12	300 kHz to 12 GHz	-80 to +23 dBm
855B-20	300 kHz to 20 GHz	-80 to +20 dBm
855B-33	300 kHz to 33 GHz	-50 to +19 dBm
855B-40	300 kHz to 40 GHz	-50 to +18 dBm

Features

- Very low phase noise at 1 GHz and 20 kHz offset: -145 dBc/Hz
- Fast switching: 500 μ s and 25 μ s with option FS
- Phase-coherent, phase-coherent switching, phase memory
- Independently adjustable channel phase
- Analog modulation

Model 870A Series

Multi-Channel High-Purity SGs



The 870A multi-channel SG family consists of various models supporting up to 54 GHz. The multiple outputs are phase-coherent and exhibit excellent phase noise and spurious performance. All the channels are independently adjustable. Optionally, they also have features of phase-coherent switching and phase memory.



MODELS	DESCRIPTION	OUTPUT POWER
870A-12	9 kHz to 12.75 GHz	-120 to +20 dBm
870A-20	9 kHz to 20 GHz	-120 to +20 dBm
870A-40	9 kHz to 40 GHz	-120 to +20 dBm
870A-50	9 kHz to 54 GHz	-120 to +20 dBm

Features:

- Very low phase noise at 10 GHz and 20 kHz offset: -130 dBc/Hz
- Low spurious: -85 dBc; harmonics: -50 dBc
- Fast switching: 5 μ s with option FS
- Phase-coherent, phase-coherent switching, phase memory
- Independently adjustable channel phase
- Pulse and analog (AM/FM/PM) modulations

Model 875 Series: Multi-Channel RF/MW VSGs



Wideband I/Q modulation, ultra-agile switching / sweeping / chirping.
Internal AWG. I/Q data playback and streaming, fast control port...



MODELS	DESCRIPTION	OUTPUT POWER
875-04	10 MHz to 4 GHz	-120 to +17 dBm
875-06	10 MHz to 6 GHz	-120 to +15 dBm
875-12	1 kHz to 40 GHz	-120 to +15 dBm
875-20	1 kHz to 51 GHz	-120 to +19 dBm
875-40	10 MHz to 40 GHz	-120 to +14 dBm

Features:

- Ultra-fast switching: $<1 \mu\text{s}$ within mod BW; $2 \mu\text{s}$ wide-band
- Low phase noise: -145 dBc/Hz at 1 GHz, 20 kHz offset (-115 dBc/Hz at 40 GHz, 20 kHz offset)
- 400 MHz digital and 100 MHz analog modulation bandwidth
- Internal baseband SG: 500 MHz sampling, 512 Msa memory

Phase Coherence (1)



Phase Coherence at 5 GHz

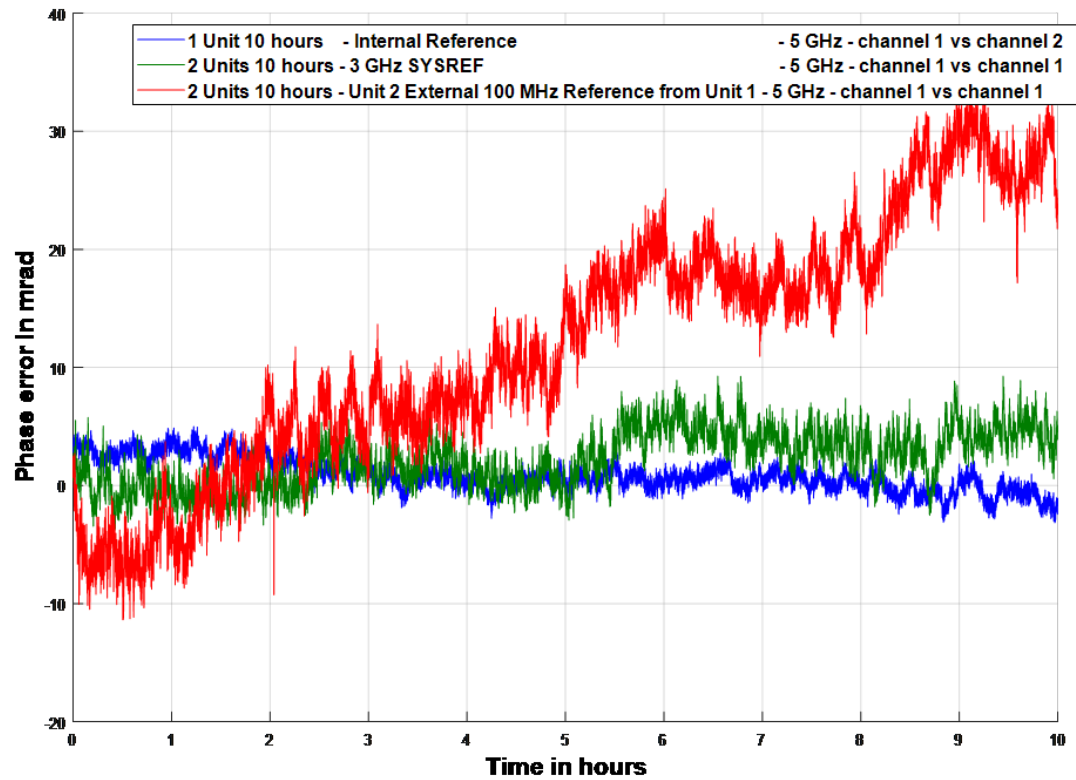

Phase coherence between 2 different frequencies

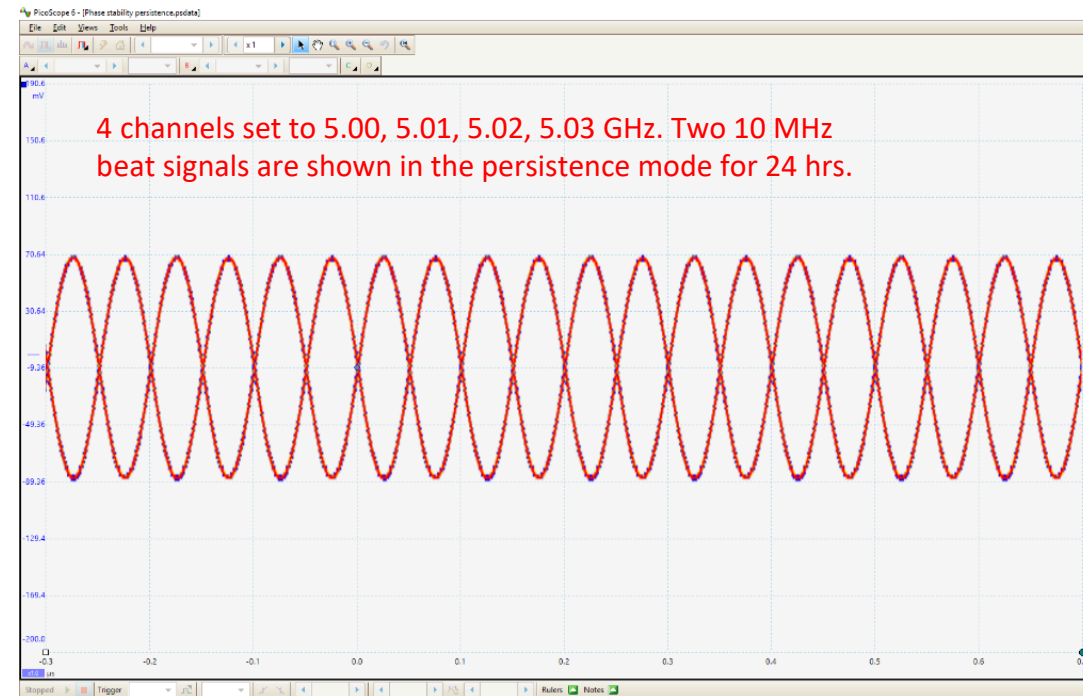

Phase Coherence (2)



How to reach the excellent phase coherence:

- Each 855B/875 module has a common highly stable OCXO frequency reference. Frequencies of all channels are digitally synthesized / derived from the common reference frequency with high resolution.
- Same frequency synthesis circuitries of the parallel channels ensures the maximum phase coherence.
- All the channels in the 855B and 875 module are in a similar ambient environment that ensures min. drift difference.
- Each module features a pair of high-frequency clock ports (3 GHz for 855B or 6 GHz for 875) allowing for excellent phase synchronization between the multiple 855B/875 modules.
- Flexible synchronization to different external references: 10 MHz, 100 MHz, 1 GHz, and even a reference range of 5 to 250 MHz

Phase Coherent Switching



Phase Coherent Switching:

The relative phase between channels 1 and 2 (signal 1 and 2) remains the same after channel 2 temporarily switched to a different frequency.

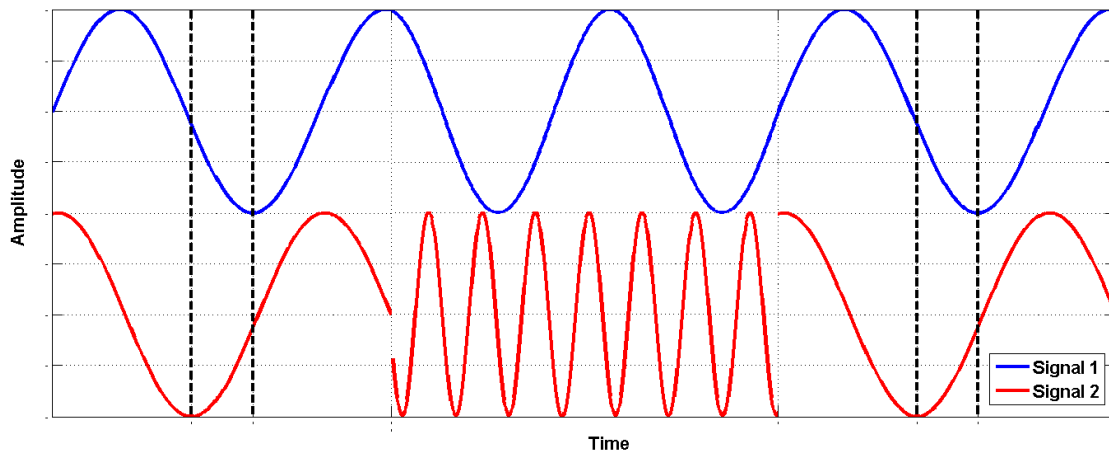

Phase Memory:

The signal returns to the same absolute phase when returning to the previous frequency and amplitude setting.

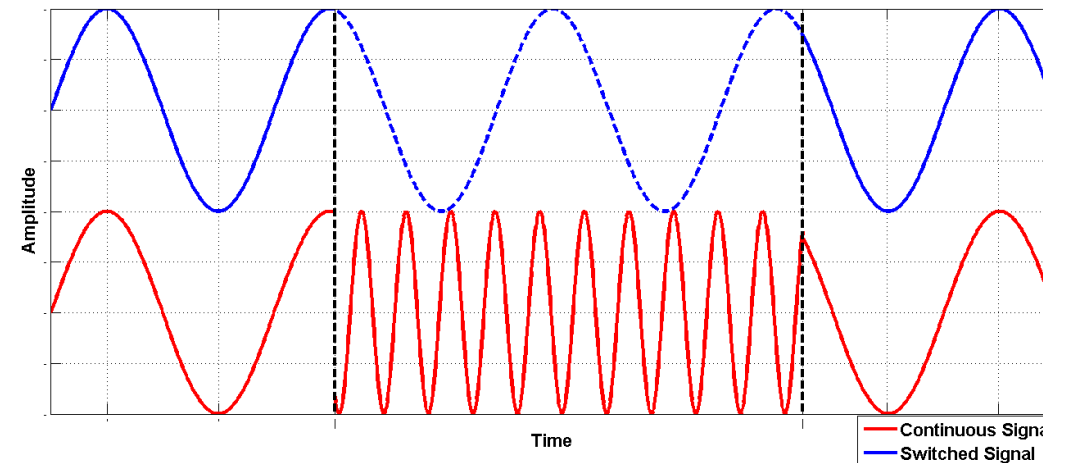

Competitive Comparison

VSGs for Quantum Computing



	BNC 875	R&S SMCV100B	ZI SHFSG 8.5 GHz	R&S SGS100A
Single- / Multi- Channels	Yes / yes	Yes / no	4 or 8 channels	Yes / yes (ext ref sync)
Frequency range	10 MHz to 4 / 6 / 12 / 20 / 40 GHz	3 / 6 / 7.125 GHz	DC to 8.5 GHz	80 MHz to 6 / 12.75 GHz
Switching time	< 100 ns within 400 MHz < 2 us over entire range	< 5 ms	?	500 us
Ext. Ref. In	10 / 100 MHz, 3 GHz	10 MHz	10, 100 MHz	10, 13, 100, 1000 MHz
Ref. Out	10 / 100 MHz, 3 GHz	10 MHz	10, 100 MHz	10, 1000 MHz
Output power range	-120 to +20	-120 to +15 dBm HP option	-30 to +10 dBm	-120 to +15 dBm with option B26
Phase Noise @ 20 kHz offset		Standard / with Option K709	Phase Noise (@ 6 GHz): -90 dBc/Hz @ 1 kHz offset -98 dBc/Hz @ 10 kHz offset -100 dBc/Hz @ 100 kHz offset	
1 GHz	-145 dBc/Hz	-112 dBc/Hz / -135 dBc/Hz		-133 dBc/Hz
7.125 GHz	-115 dBc/Hz	-112 dBc/Hz / -112 dBc/Hz		
40 GHz	-115 dBc/Hz			
Phase coherence	Yes	?	?	Yes, Option K90
I/Q Modulation				
Mode	Internal BB I/Q	Internal BB I/Q		No int. BB IQ generator
Modulation Bandwidth	400 MHz	240 MHz		
Digital I/Q input	Yes	Yes	No	No
I/Q sampling rate	125 / 250 MHz max	75 / 140 / 200 / 300 MHz		
Analog I/Q input	Yes, 50 MHz	No	Yes, 1 GHz BW	Yes, 1 GHz BW
Waveform length	512 Msample max, 32 bits	512 Msample max, 16 bits	98 kSa per channel	No
Custom digital modulation	Option IVM	ASK, FSK, PSK, QAM (option K199)	No	No
Basic AM/FM/PM	Yes, internal (option MOD)	Yes, internal (option K197)	No	No
Pulse Mod	Yes, internal (option MOD)	Yes, internal (option K198)	No	Yes, K22
AWGN	Yes, Internal	Yes, K62	No	No

MW Frequency Synthesizers

Radar

Automated Testing

Microwave

5G Wireless Communication



Frequency Synthesizers



MODELS	DESCRIPTION	OUTPUT POWER
845-M	10 MHz to 20 GHz	+23 dBm
865B-M-40	8 kHz to 43 GHz	-10 to +25 dBm
825-M	100 kHz to 20 GHz	0 to +18 dBm
805-M	100 kHz to 22 GHz	-40 to +25 dBm
866-M	1 MHz to 40 GHz	-30 to +25 dBm
805-SG	8 kHz to 20 GHz	-25 to +16 dBm

Features:

- Low phase noise and fast switching
- High harmonics suppression. 865B-M-40: -50 dBc with option FILT.
- LAN, USB, SPI, control interfaces
- Single- or multi-channel models
- FM, PM, Pulse Modulations

Instrument-Grade Synthesizer

805-SG



MODELS	DESCRIPTION	OUTPUT POWER
805-SG	100 kHz to 22 GHz	-20 to +18 dBm
Features: <ul style="list-style-type: none"> • Harmonics -50 dBc; spurious -80 dBc; • Phase noise -127 dBc/Hz @ 20 kHz from 10 GHz. • Pulse modulation • “NI QuickSyn” replacement 		

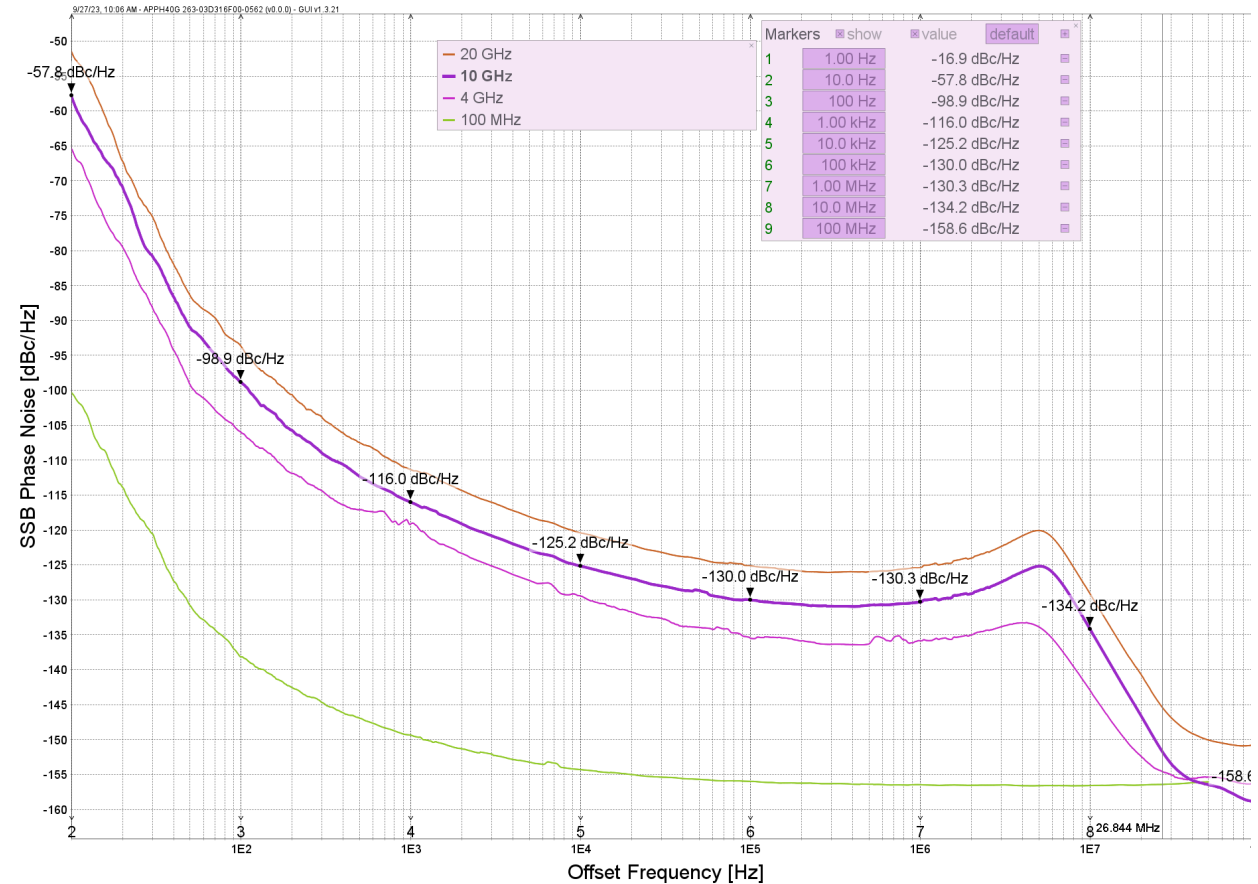

805-SG

Harmonics and Non-Harmonics

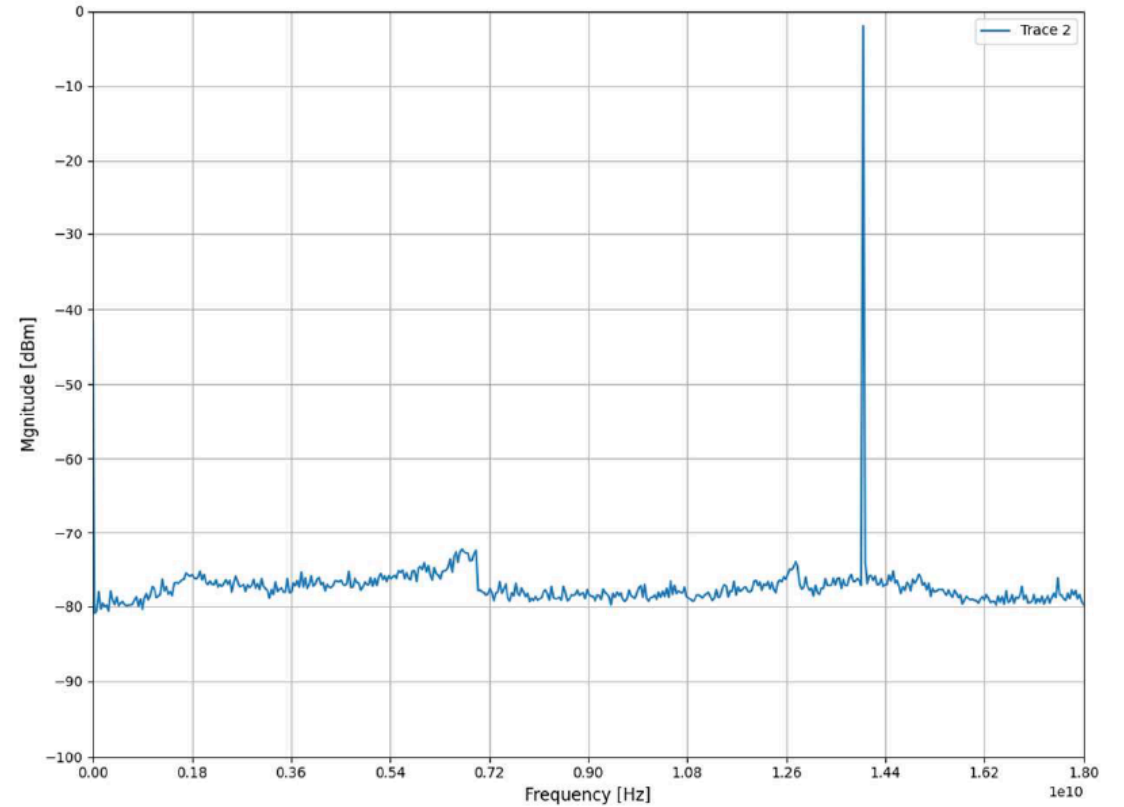
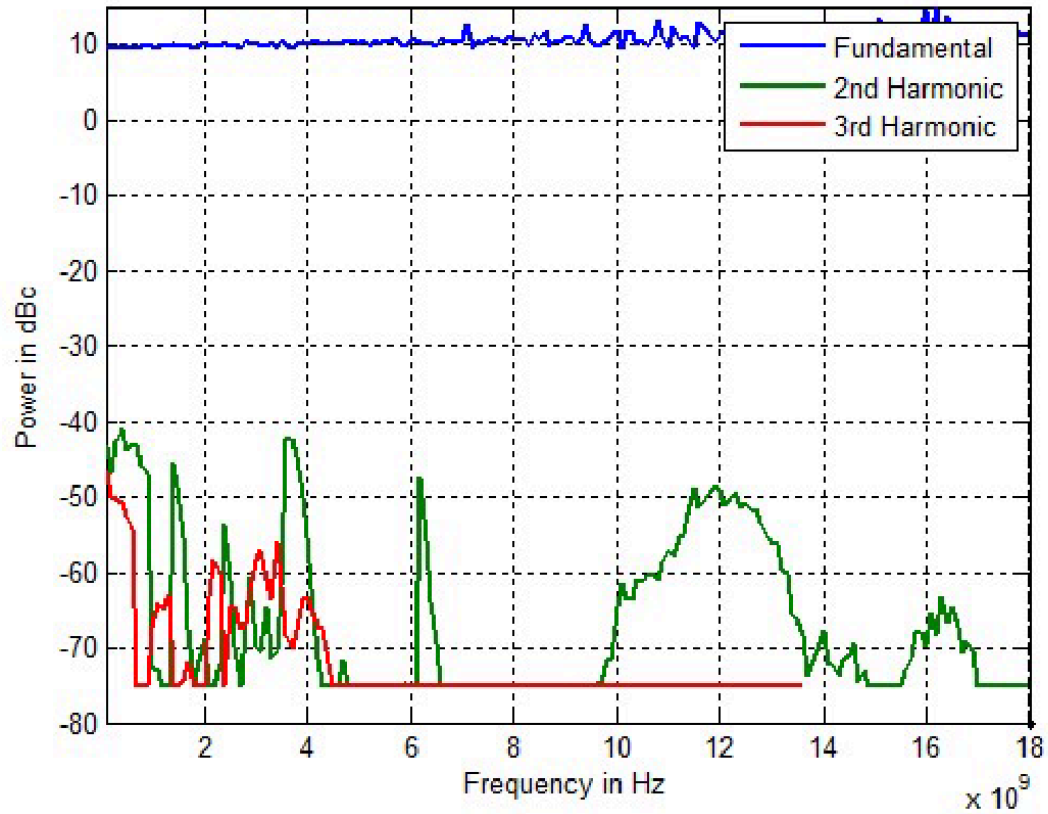

805-SG

Drop-In Replacement and Upgrade of NI QuickSyn FSW-002



- High-purity local oscillators
- Drop-in replacement of FSW-0020 and FSW-0010
- Reference frequency module for T&M instruments
- Precise system clock
- Radar / EW
- Quantum computing

Parameter	NI FSW-0020	BNC 805-SG
Frequency range	0.2 to 20 GHz	8 kHz to 20 GHz
Switching speed	100 μ s (list sweep) 200 μ s (over SPI)	20 μ s (list sweep) 200 μ s (over SPI)
Power range	-10 to +13 dBm @ > 0.5 GHz	-25 to +16 dBm @ > 1 GHz
Level accuracy	\pm 2.0 dB	\pm 0.3 dB
Phase noise @ 100 Hz / 10 kHz / 1 MHz from 10 GHz:	-83 / -122 / -126 dBc/Hz	-95 / -126 / -130 dBc/Hz
Harmonics / Non-harmonics	-35 / -70 dBc @ > 0.5 GHz	-50 / -70 dBc @ > 0.1 GHz
Modulations	Pulse, AM/FM	Pulse, AM/FM
Reference in/out	10 MHz	10 MHz, 100 MHz, 1 GHz
Communication ports	SPI, USB	SPI, USB, Ethernet
Power supply and consumption	12 VDC / 20 W	12 – 30 VDC / 24 W

805-SG

vs. FSW-0020



Parameter	NI FSW-0020	BNC 805-SG-1
Frequency range	0.2 to 20 GHz	8 kHz to 20 GHz
Switching speed	100 μ s (list sweep) 200 μ s (over SPI)	20 μ s (list sweep) 200 μ s (over SPI)
Power range	-10 to +13 dBm @ > 0.5 GHz	-25 to +16 dBm @ > 1 GHz
Level accuracy	\pm 2.0 dB	\pm 0.3 dB
SSB Phase noise @ 100 Hz, 10 kHz, 1 MHz from 10 GHz:	-83 / -122 / -126 dBc/Hz	-95 / -126 / -130 dBc/Hz
Harmonics / Non-harmonics	-35 / -70 dBc @ > 0.5 GHz	-50 / -70 dBc @ > 0.1 GHz
Modulations	Pulse, AM/FM	Pulse, AM/FM
Reference in/out	10 MHz	10 MHz, 100 MHz, 1 GHz
Communication ports	SPI, USB	SPI, USB, Ethernet
Power supply and consumption	12 VDC / 20 W	12 – 30 VDC / 24 W

Frequency Synthesizers



- Compact size for instrument-embedding and system integration
- Multi-channel configurability with 1 GHz common reference use for Phase Coherence
- 805-M PhN behavior like 845, 825-M; 866-M-40 PhN behavior like 865, 855B, 865B-M; 805-SG-1 PhN behavior like 870A
- Very cost-efficient signal sources 20 / 40 GHz, in desktop / portable form, if no AM and wide power range adjustment needed.
- Lower cost alternatives to 855B: 825-M, 865B-M for Quantum Computing: RFLOs to IQ mixers, and for pumping the parametric amplifiers

Single- and Multi-Channel 875 Applications



- Generation of standard wireless communication signals (5G, 6G, BT, WiFi, GNSS, etc.) with 3rd party software
- **Radar, EW**
 - PDW playback and streaming
 - Fast freq hopping (communication and jamming)
- **Quantum Computing:** Generation of QuBit manipulation signals
- Avionics modulation signals
- EMC testing: multi-carrier with user-definable carrier modulation
- Power bank supported field applications



RF & MW Signal Sources Relevant for Radar & EW



Enabling Features:

- Compact size and low power consumption
- Single- and multi-channel configurability
- Fast Power and Frequency Switching
- Low Phase Noise and High Signal Purity
- Multi-Channel Sources:
 - Phase Coherence
 - Phase-Coherent Switching
 - Channel-Individual Phase Adjustment
 - 875-X:
 - * PDW (Pulse Descriptor Word) Playback and

Streaming

- * Waveform and Time Base Synchronization
- * Phase Calibratable Mode

Radar & EW Application Scenarios



Vehicle- Submarine- and Air-Borne Radar Systems



Communication and Jamming

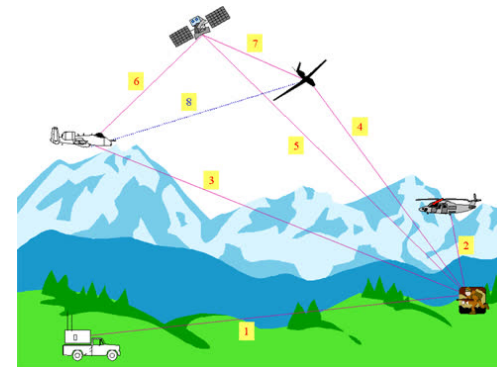

Radar Path Calibration w/ Powerbank Operated SGs



Model 875 for Radar and EW:

Main Operation Modes



- Compilation of I/Q files / segments; upload to 875 internal RAM; (segment ID selective) playback
- I/Q file streaming through FCP (Fast Control Port): **Option FCP**
- Compilation of PDW lists; Upload to 875; real-time interpretation to I/Q data; playback: **Option PDW**
- PDW list streaming through FCP (Fast Control Port): **Option FCP**

- Ultra-fast switching: **Option UFS**
- Phase-coherent switching: **Option PHS**
- Time base synchronization: **Option SYNC**
- Phase-calibratable mode: **Option PCM**

Pulse Descriptor Word: Playback and Streaming



Mode 1: PDW List Upload & Playback

A list of PDWs (precompiled file describing pulse sequence parameters) is uploaded into the 875 internal memory. During the playback, each PDW is translated to the corresponding modulation parameters in real-time for signal generation.

Mode 2: PDW Streaming

PDWs are fed into the 875 internal memory in real-time through the FCP (Fast Control Port) for immediate playback as described in mode 1.

(AN6008: Pulse Descriptor Word for 875)

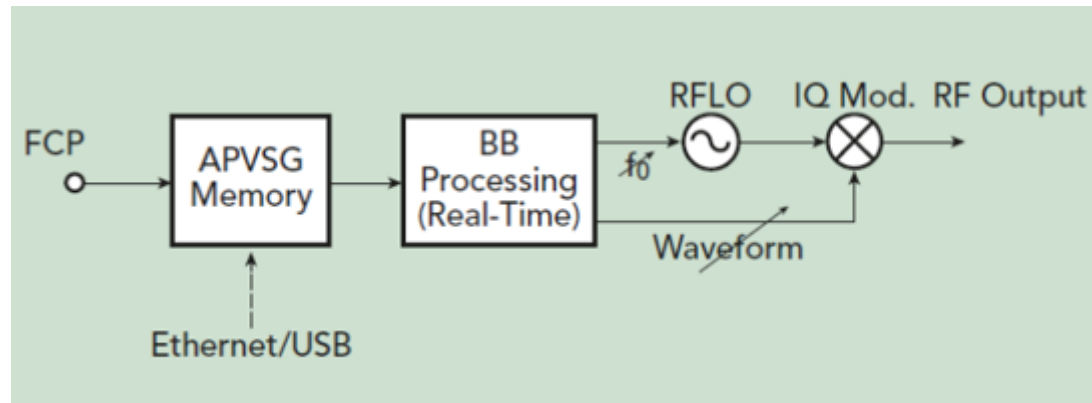

PDW (Pulse Descriptor Word) Structure



Address Range	Parameter Name	Parameter Group
1	PDW Configuration	PDW Setting
2 – 3	Reserved	
4	PDW Modulation	
5 – 6	Reserved	
7	PDW Marker	
8 – 15	Reserved	
16 – 23	Start Time	PDW Timing
24 – 31	Pulse Width	
32 – 33	Waveform Segment	Waveform Modulation
34 – 47	Reserved	
48	RF Output	Carrier Output
49 – 54	Frequency	
55 – 56	Power	
57 – 58	Fixed Phase	
60 – 69	Reserved	Offset
70 – 89	Reserved	FM/PM
90 – 97	Reserved	AM
98 – 105	Reserved	Chirp
106	Sweep On Pulse	Phase Sweep
107 – 108	Phase Step	
109 – 116	Sweep Dwell Time	
117 – 124	Sweep Step Time	
125 – 255	Reserved	Reserved

PCM: Phase Calibratable Mode



- With option PHS, the 875 guarantees deterministic and reproducible phase relations between individual channels and devices.
- Deterministic and reproducible, however, means that those phase relationships may still vary with power and frequency settings. Varying RF path configurations (gain and attenuation settings must be adjusted) cause jumps in the phase relationship over power and frequency setting. Thus, phase calibration is only feasible for selected combinations of power and frequency. Covering a broader range of power and frequency would require a very high number of phase calibration points, causing prohibitively long calibration measurement times.
- PCM addresses that shortcoming by using less, and therefore larger, ranges over power and frequency using a common RF path configuration and thus generating stable phase relationships.
- Power setting accuracy and resolution is maintained by scaling IQ modulation data instead of adjusting RF path gain or attenuation.

(AN6011: Phase Calibratable Mode for 875)

PCM:

Effect of PCM



Advantages of PCM

- Static phase relationships over power level.
- Linear phase relationships over frequency.
- Phase calibration over a larger or even the full power and frequency range is possible with only a few calibration points.
- PCM has no impact on switching speed. PCM is fully supported in ultra-fast switching (UFS) mode, e.g., with pulse descriptor word (PDW) playback.

Impact of IQ Scaling

Advantages of PCM

- Effective # of bits decreases with bigger IQ scaling range.

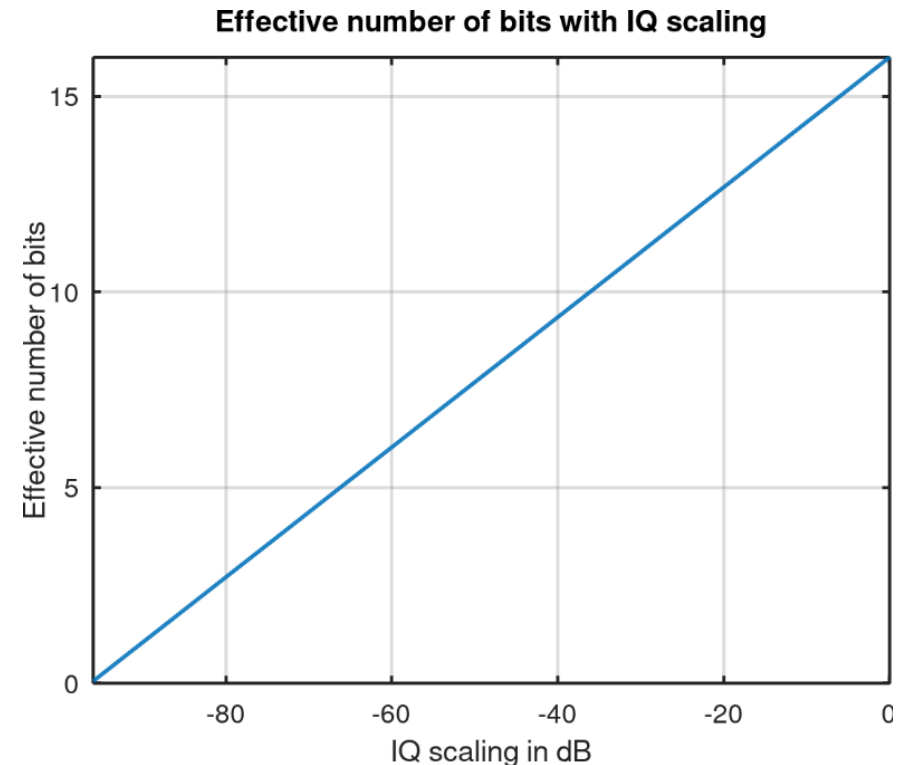

Phase vs. Power and Frequency

Before and After Calibratable Mode

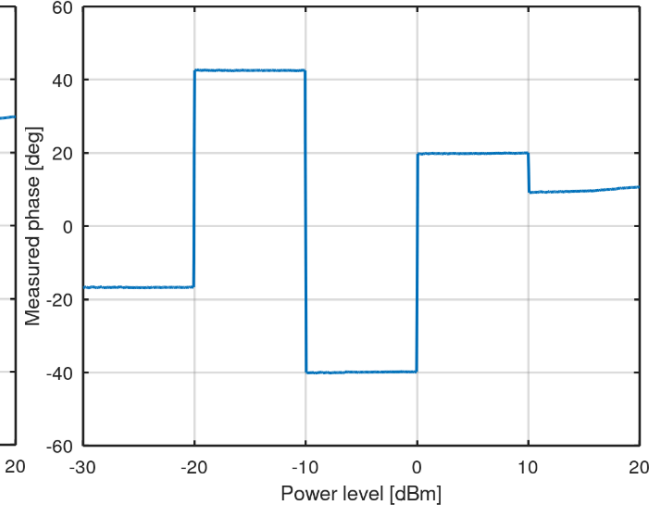
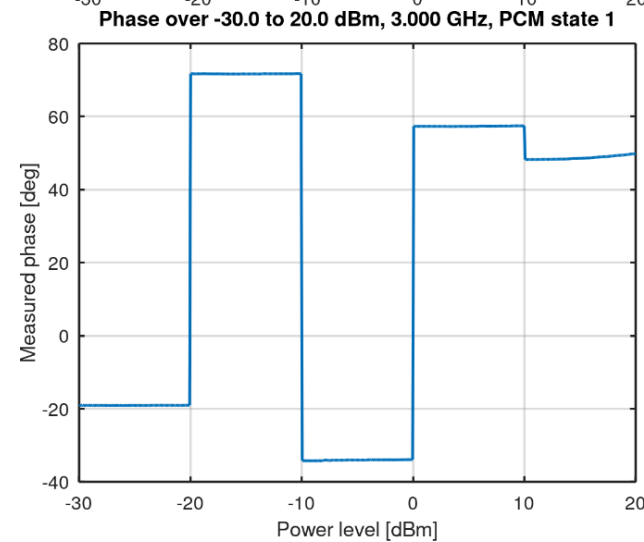
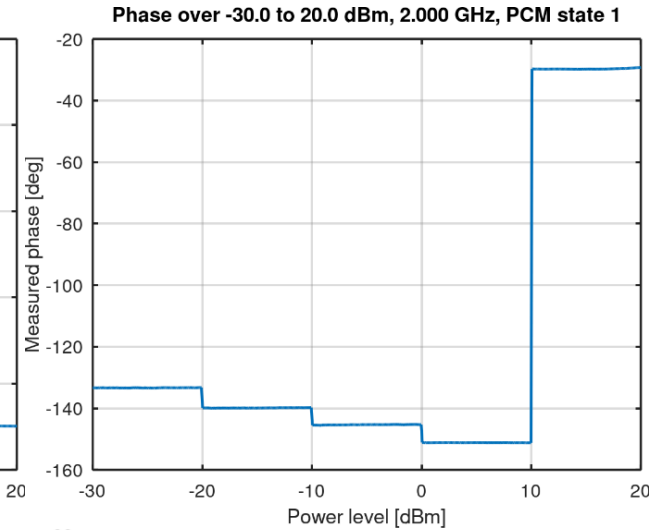
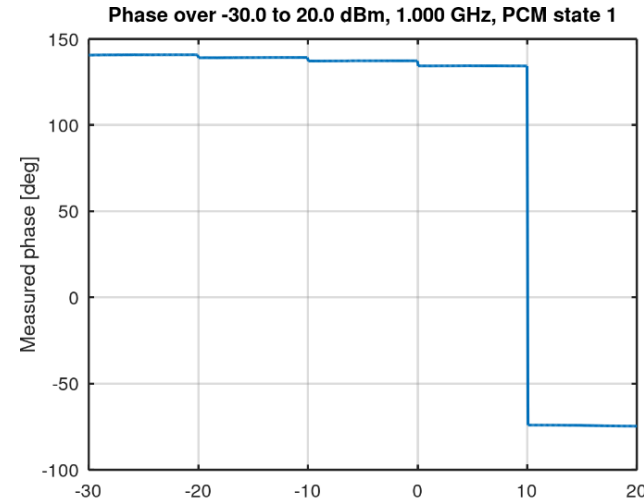
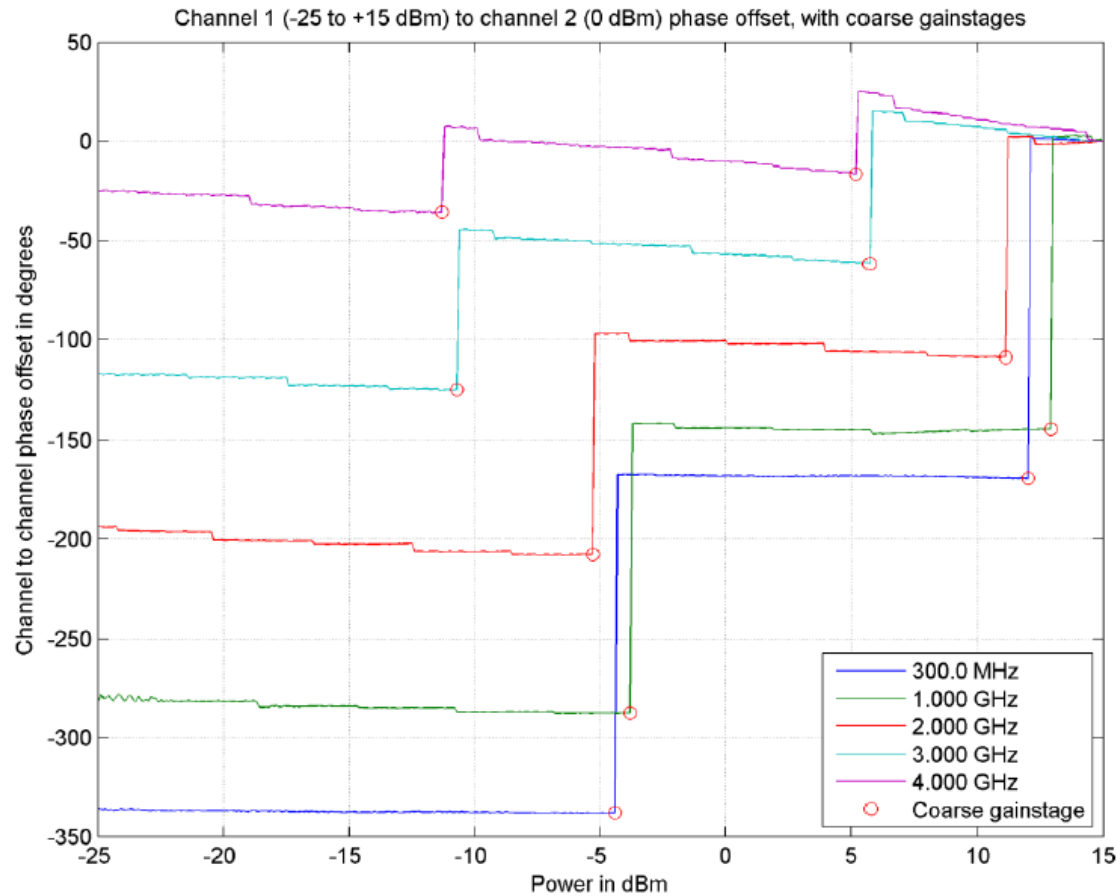

Phase vs. Power and Frequency

After RF Phase Calibration

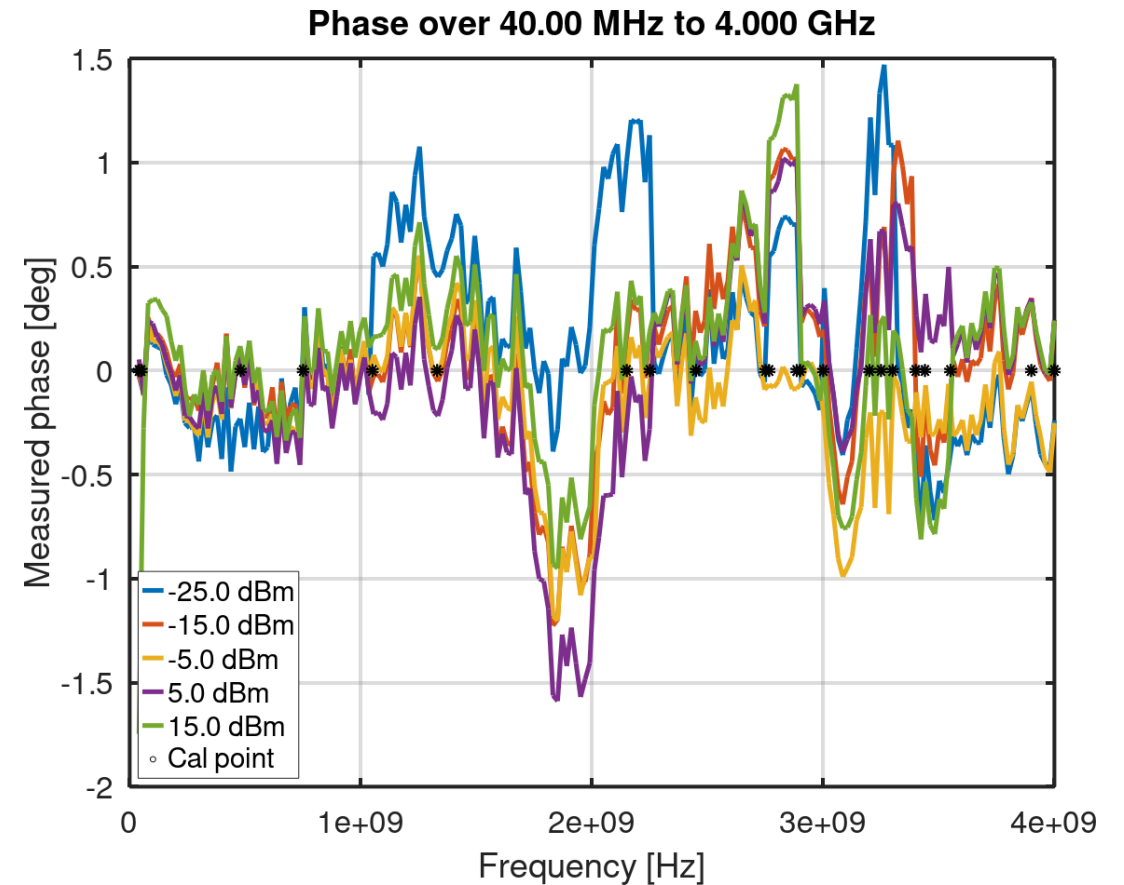
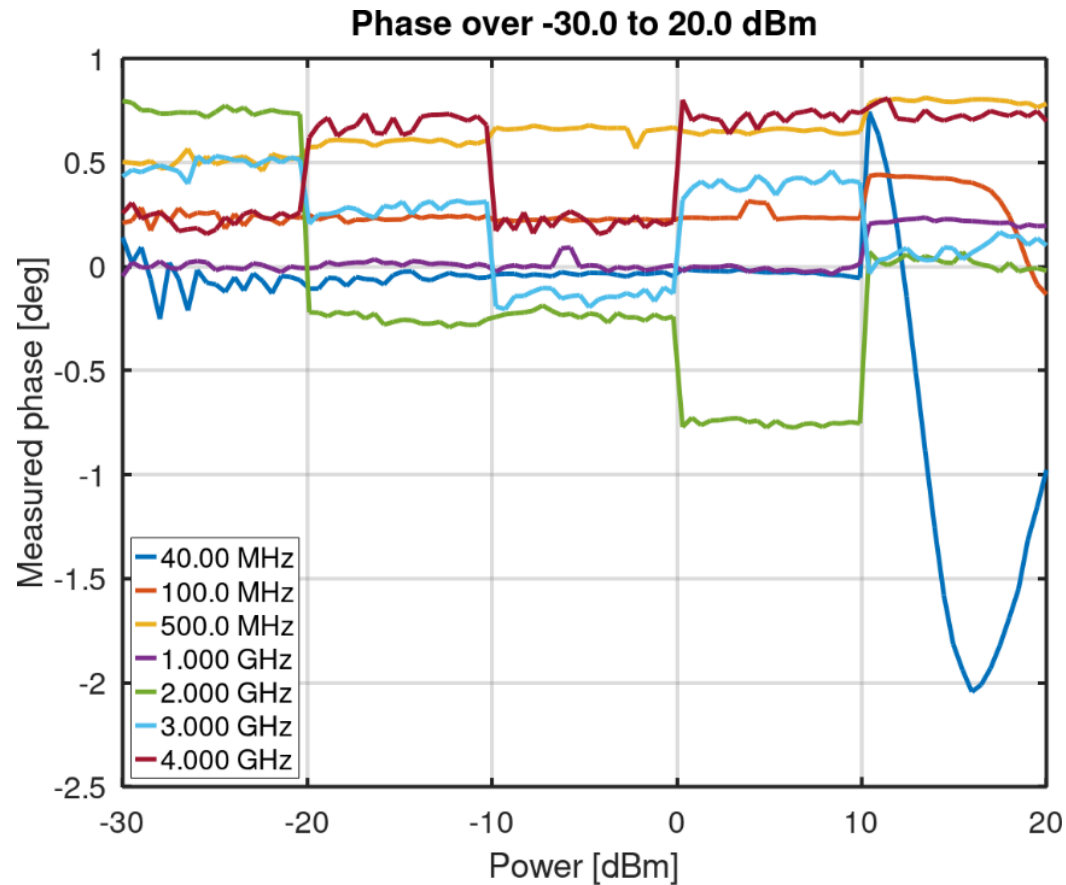

Model 855B / 825-M and 875 for Quantum Computing

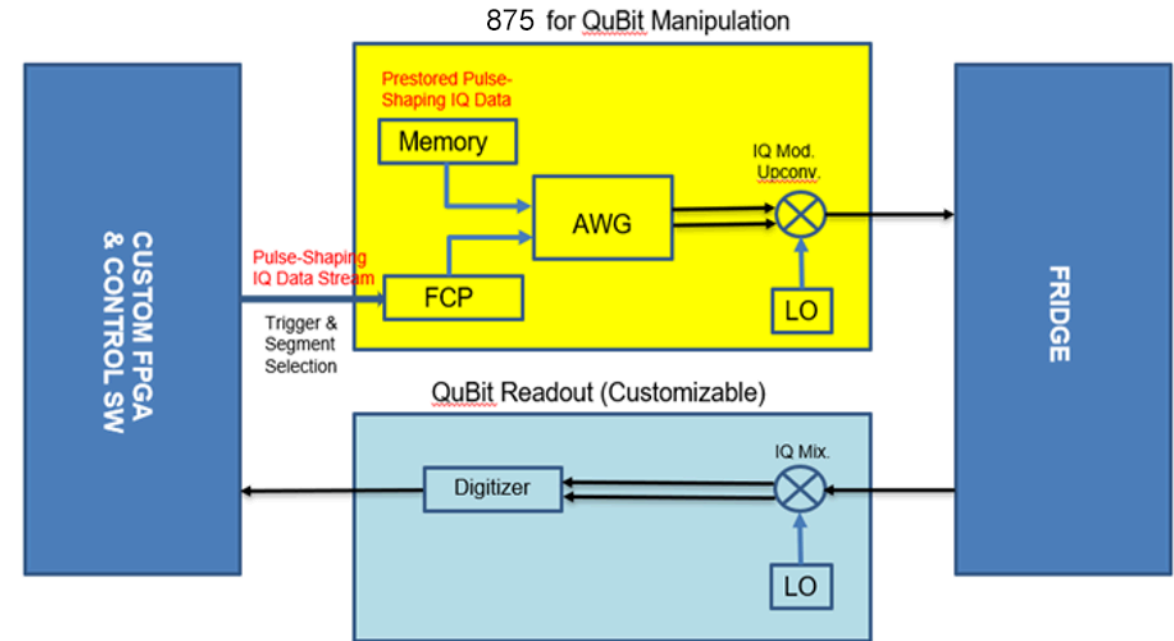
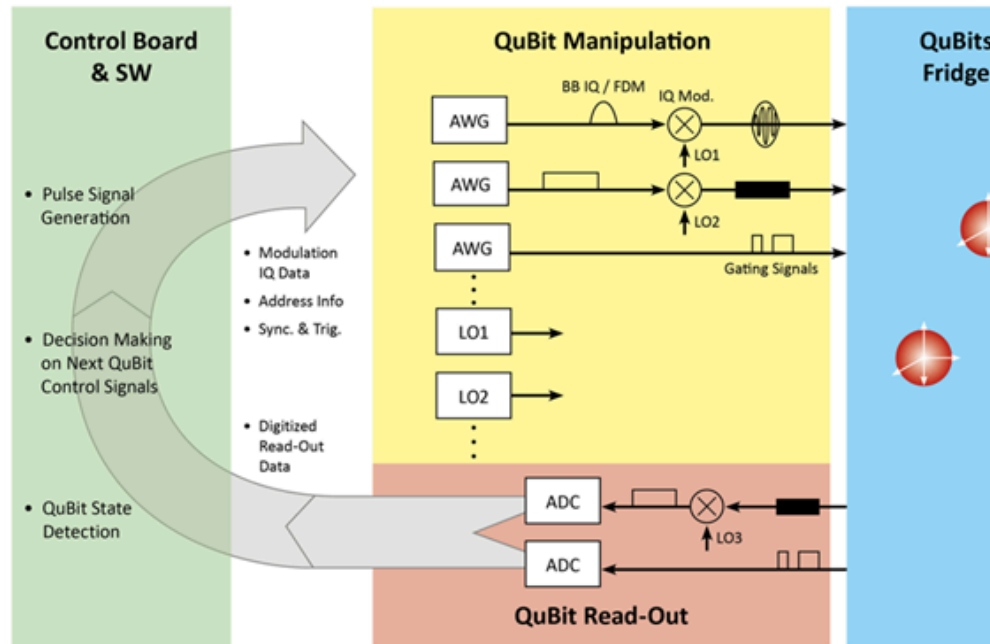

- 855B (825-M): RFLOs, Pumping Sources for parametric amplifiers
- 875: for multi-QuBit manipulation signal generation
- Phase-coherence, low phase noise, low latency, compact design, low power consumption ...

Signal Source Analyzers

Time and Frequency Standard Research

RF and Microwave modules

Communications



Signal Source Analyzers



MODELS	
7070	1 MHz to 7 GHz
7300	1 MHz to 26 GHz
7340	1 MHz to 40 GHz
7450	1 MHz to 50 GHz (Mid 2024)
7465	1 MHz to 65 GHz (Mid 2024)

Key Features:

- Easy operation: PC based GUI software, remote control through LAN, USB, GPIB
- Single broadband input from 1 MHz to 7 ... 65 GHz
- Low noise floor (< -190 dBc/Hz)
- Offset range: 0.01 Hz to 100 MHz
- Flexible internal and external references
- Built-in 3 independent tuning voltages (-5 to +22 V)
- Built-in 2 independent DC supply voltages (0 to 15 V, 600 mA each)
- External 10 MHz reference input
- External trigger input
- Light weight: 11 kg and compact size

Signal Source Analyzers

Key Functions



Description

Key functions:

- Phase Noise Measurement
 - Absolute, residual / additive
 - CW, pulse, burst (time-gated) measurement modes
 - High-drift or slowly modulated
 - With internal or external references
- Amplitude Noise Measurement
 - Absolute Noise Measurement
 - Absolute
 - CW and Pulse measurement modes
 - High-drift or slowly modulated
 - Always with internal references
- Transient Measurement (Frequency, Phase, Amplitude vs. Time)
- Short- and Long-Term Frequency Stability / Allan Deviation Measurement: 1 s ... 10 days
- Complete One-Step VCO Characterization (Tuning, Tuning Sensitivity, Pushing, Power, Harmonics, Current, Phase Noise)
- Baseband FFT Analyzer (base-band 1 Hz to 100 MHz)
- Spectral Analysis (5 MHz to 65 GHz)



Signal Source Analyzers

Options



OPTION	DESCRIPTION	SUPPORTED MODELS
Option LN	Enhance phase noise test sensitivity (HW)	All
Option PULSE	Add pulsed measurement capability (SW)	All
Option NPS	Very Narrow Pulse measurement mode (SW)	All
Option BURST	Burst mode phase noise measurement (SW)	All
Option AM	Add amplitude noise measurement capability (SW)	All
Option APN	Additive phase noise measurement (SW)	All
Option TRAN	Transient measurement (SW)	All
Option TSTAB	Time stability analysis (SW)	All
Option LO	Access to two internal references (HW)	All
Option VCO	One-step VCO characterization (SW)	All
Option SPEC	Spectrum Monitoring (SW)	All

Signal Source Analyzers

Front and Rear Panels



Front

DUT in (-15 to +23 dBm)
DUT tuning voltage out (-5 to +22 V)
Ext. ref. in (up to +23 dBm)
Ext. ref. tuning voltage out (-5 to 22 V)

Rear

Baseband in 1, 2
Precision power supply voltage out 1, 2, 15 VDC, 600 mA
Ext. trigger in
10 MHz ref. in
LAN, USB, GPIB
DC Power in

Fundamental Concept

Phase Noise Testing

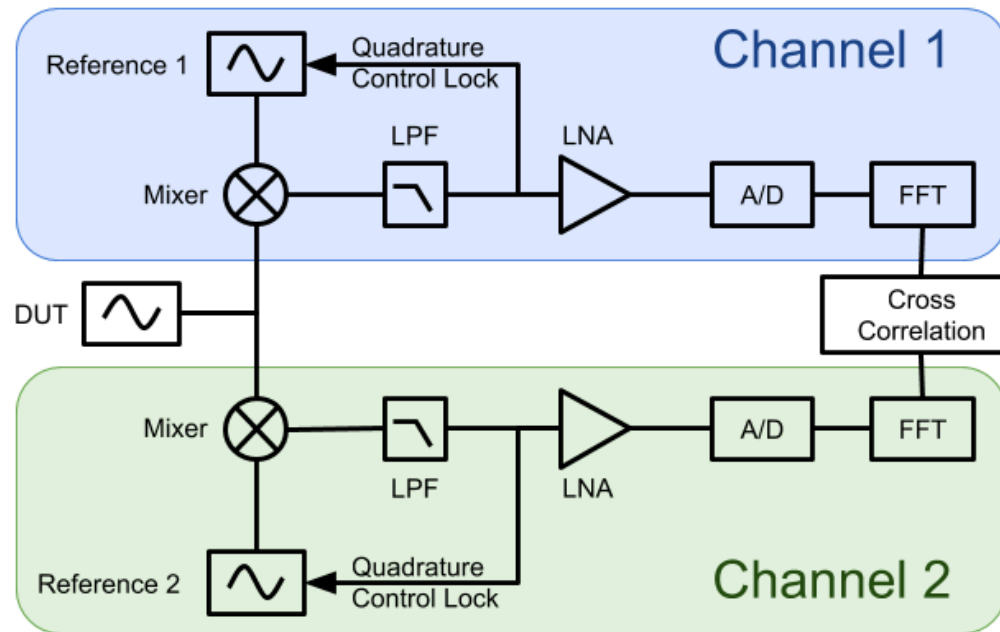

- The DUT signal is divided into two parallel branches.
- Except for high-drifting DUT, we choose to use PLL based «Zero-IF» front-end technology: before LNAs, we have baseband signals including all the noise elements.
- «Direct IF Sampling» for high-drifting DUTs.
- References can be internal or external. And in LN mode, an additional pair of high-quality references are built-in to further reduce the phase noise floor in the close-in frequency area.
- Multiple cross-correlations overcome instrument-internal thermal noise and reference (uncorrelated) noise.

Optimized Algorithm

Shortens the Measurement Time

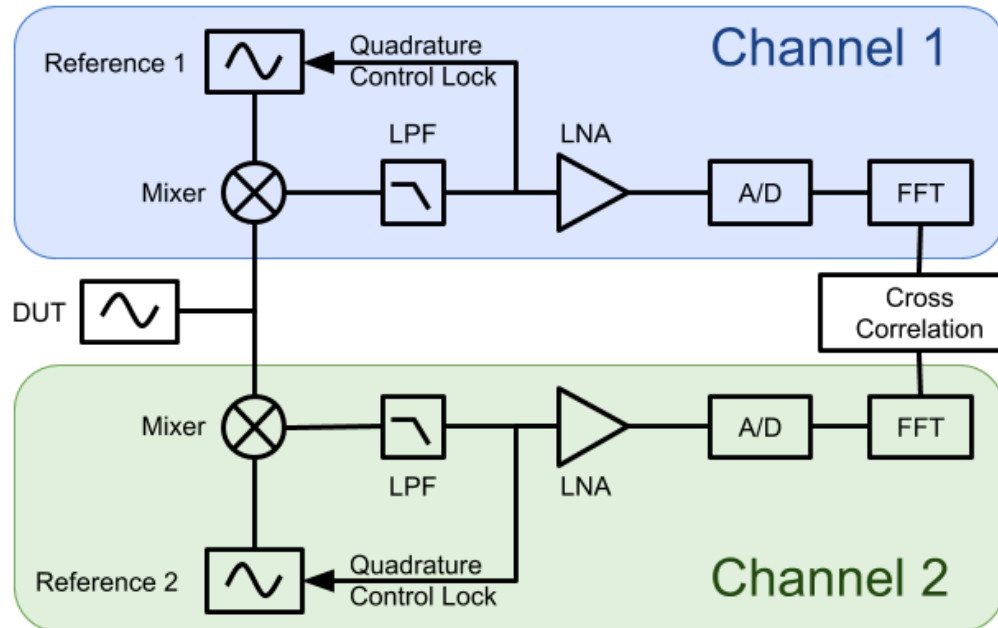

- The PhN measurement time consists of the following:
 - **7000 Series-internal Hardware Setup Time:** PLL locking, phase detector calibration, etc.;
 - **Data Acquisition Time:** Sufficient data need to be collected for meaningful statistical data processing. The higher resolution and lower offset frequency lead to longer data acquisition time;
 - **Data Processing Time:** FFT and Cross-Correlation, etc.
- 7000 Series applies following techniques to reduce the PhN measurement time:
 - Smart and adaptive choice of circuit parameters such as PLL loop bandwidth to reduce the hardware setup time;
 - Smart choice of resolution (data samples per frequency decade) to shorten the data acquisition time;
 - Highly efficient parallel processing of the data acquisition and processing.

Absolute Phase Noise Measurement

Standard and LN Mode

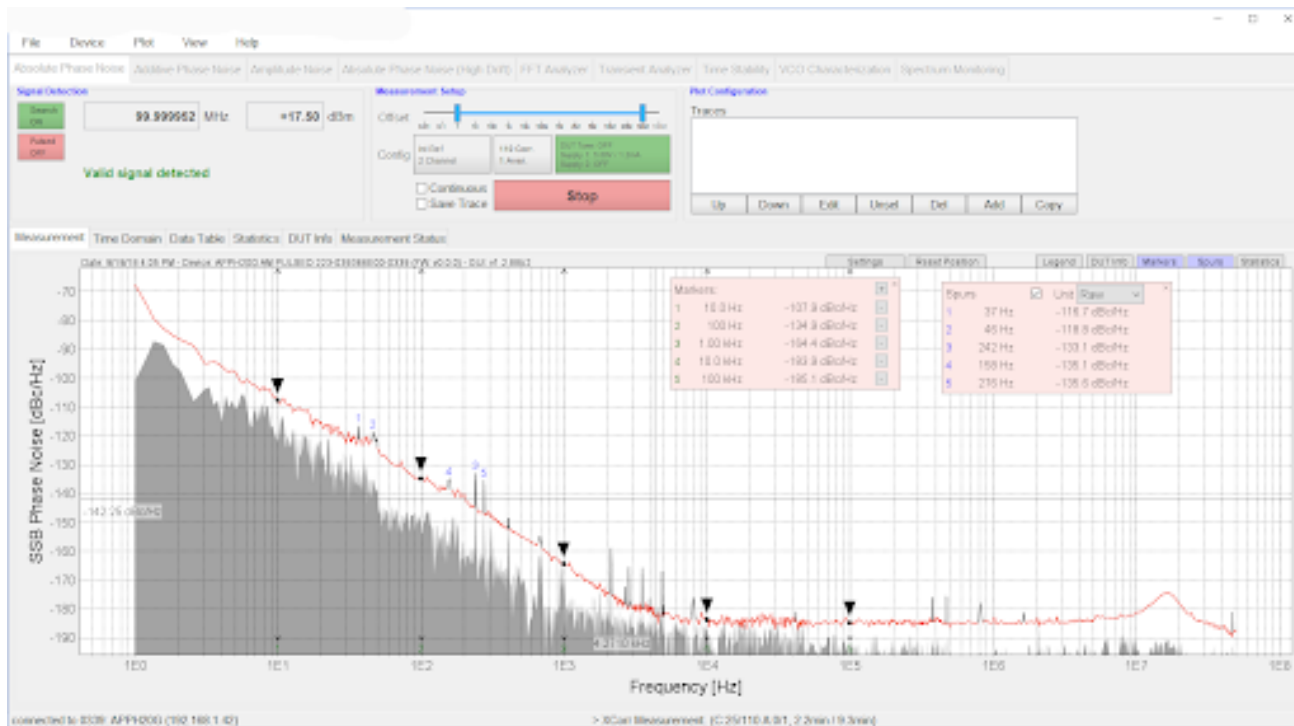

Description

- All on one GUI page
- Automatic DUT frequency search
- Frequency counter and power meter
- Adjustment of offset range, resolution, # of CC and AVG, etc.
- In the "Statistics" tab: jitter, Allen Deviation, etc.
- Spurious on / off

Absolute Phase Noise Measurement

Sensitivity Levels

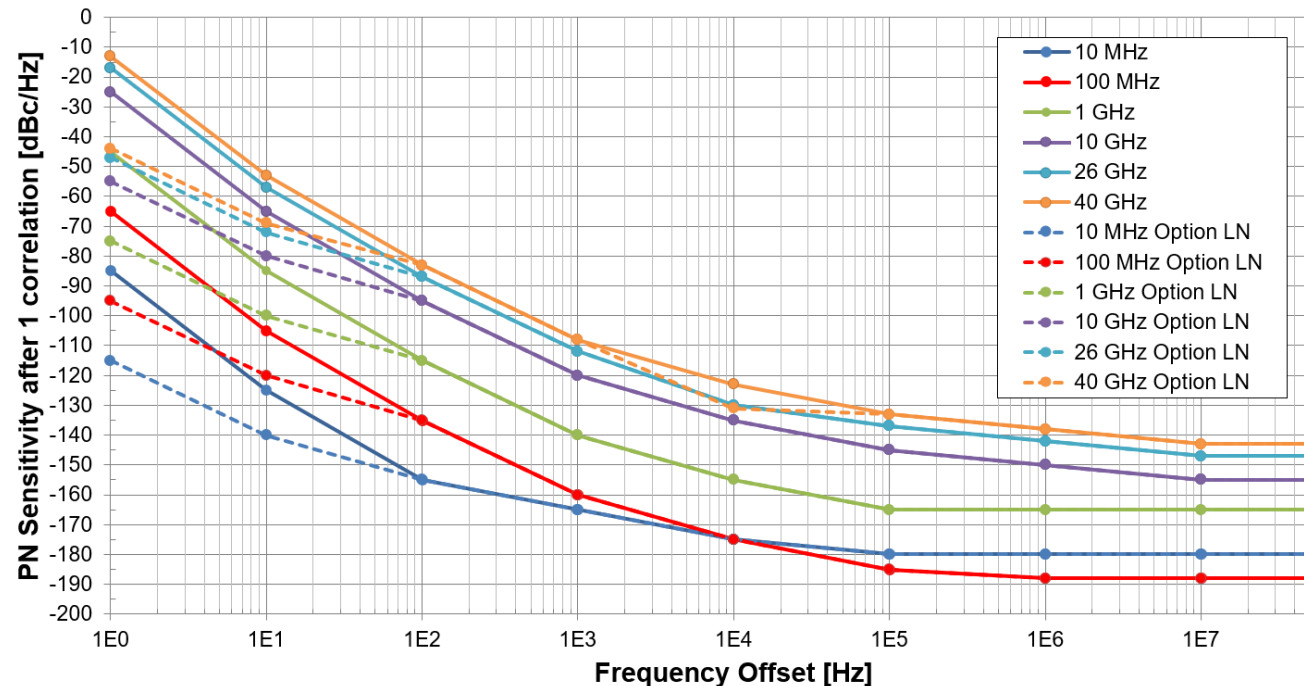

Description

- Measurements (left) done with 1 cross-correlation
- When using internal references, LN mode improves phase noise test sensitivity especially in the offset range < 1 kHz.
- Regardless with internal / external references, multiple cross-correlation further improves the measurement sensitivity:
 - 10 correlations: ~ 5 dB better
 - 100 correlations: ~ 10 dB better
 - Limit: system noise floor

Phase Noise

of Pulse Modulated Signal

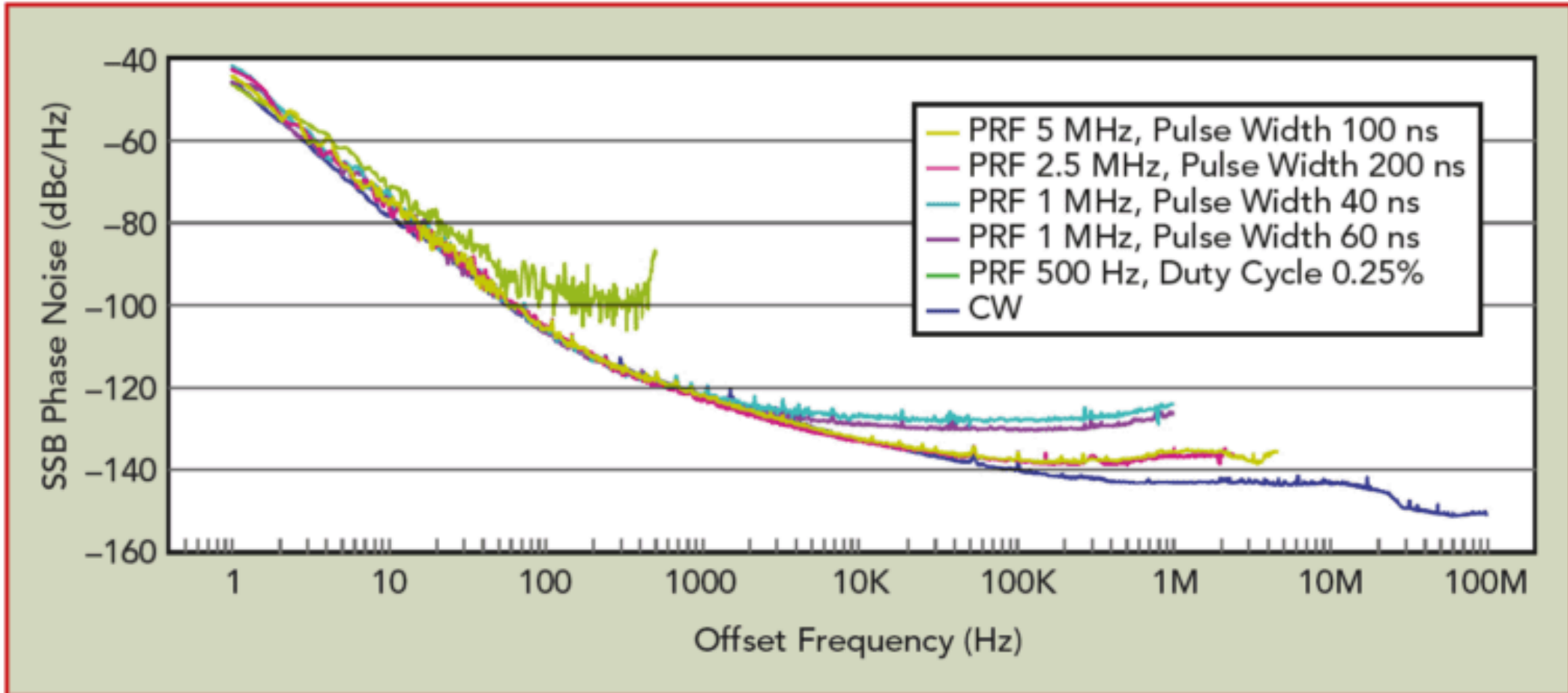

Absolute Phase Noise Measurement

With External References



Description

- The internal references, since they need to be adjustable in a wide frequency range, regardless whether it is in standard or LN mode, have significant influence on phase noise measurement sensitivity. Measuring DUTs with extremely low phase noise would then require a lot of cross-correlation and thus time-consuming.
- Using external references can reduce the number of cross-correlations, and therefore, shorten the measurement time. Choice of external references:
 - frequency-tunable (voltage control input)
 - frequency tuning ranges need to overlap with DUT frequency
 - phase noise of refs can be 10...15 dB worse than DUT's.
- Both single and dual ref channels possible.

Residual Phase Noise Measurement

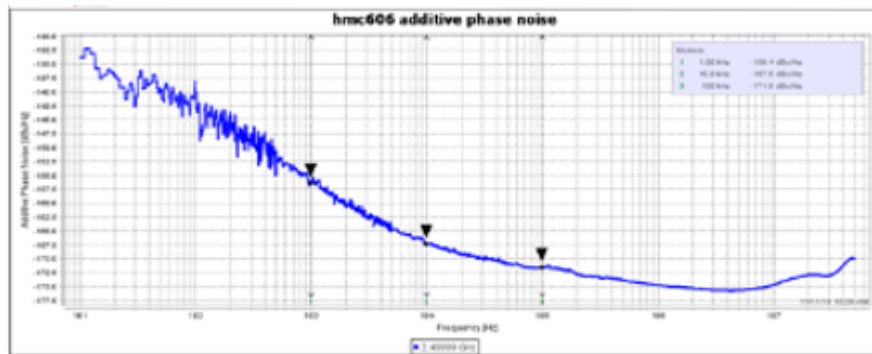
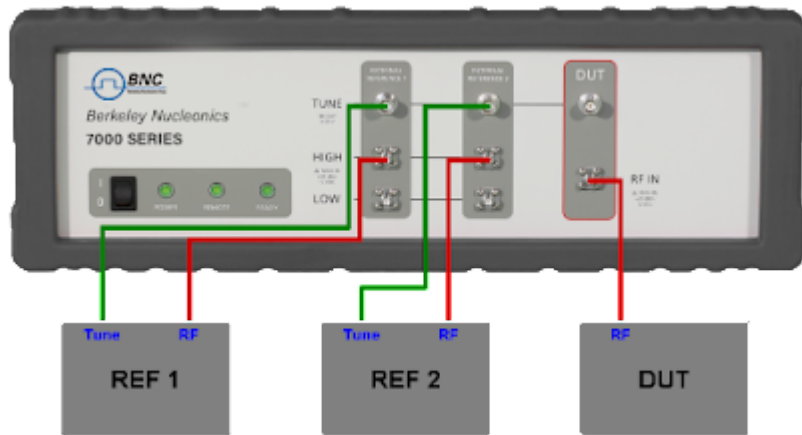

Description

- Measuring additive / residual phase noise of non-oscillating DUTs (LNA, mixer, multiplier / divisor, etc.) with extremely low instrument noise floor
- Using external signal source or internal reference source (option LO)
- Choice of accessories:
 - Oscillation source: Phase noise non-critical, but similar or better amplitude noise than the expected additive phase noise of the DUT.
 - Splitter: Good isolation, ideally non-resistive – low insertion loss
 - Phase shifter: min. 180° phase shift at target frequency
- Power balancing
 - REF IN ports need at least 13 dBm, RF (DUT) port at least 3 dBm
 - Dual-channel: REF IN power levels should be similar

Access to the Built-In References with Option LO



Connectors (Front – Option LO)



Additional RF Inputs

- LO1 IN HIGH/LOW, LO2 IN HIGH/LOW: SMA female
- RF1 IN, RF2 IN: SMA female

Additional RF Outputs

- LO1 OUT HIGH/LOW, LO2 OUT HIGH/LOW: SMA female
- RF1 OUT, RF2 OUT: SMA female

mmW Phase Noise Measurement

Using Cross-Correlated Down-Conversion



BNC 7000 Series Phase Noise Analyzer



Eravant mmW Module

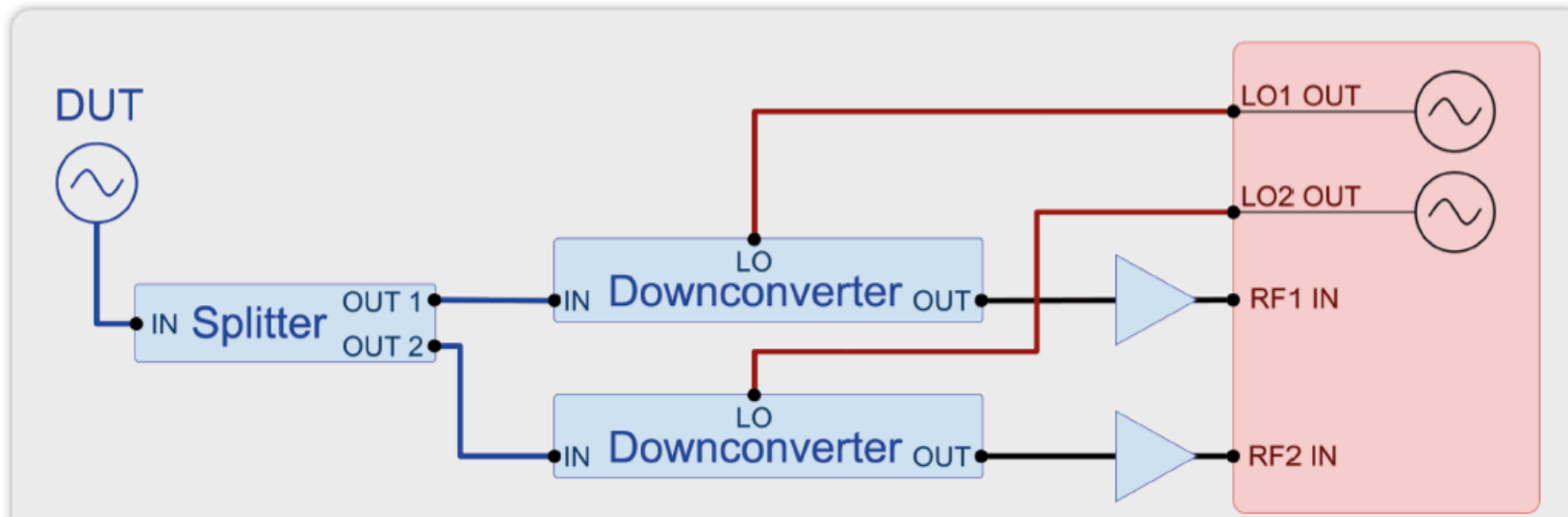

Amplitude Noise

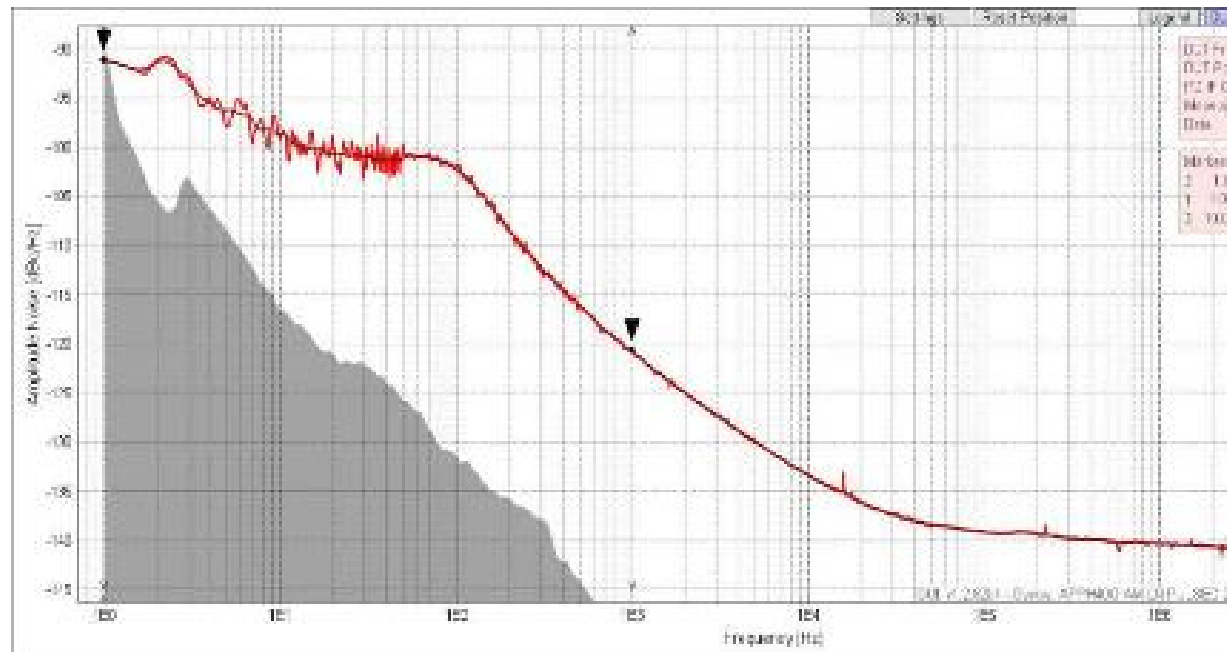

Description

- Frequency range: up to 7 / 18 GHz
- Input power range:
 - 1 MHz to 10 GHz: -20...+20 dBm
 - 10 GHz to 18 GHz: -10...+20 dBm
- Offset Analysis Range: 0.1 Hz to 40 MHz
- No PLL, direct sampling
- Cross-Correlation further reduces measurement noise floor

Pulse & Amplitude Noise Measurement

in Pulse and Burst Mode

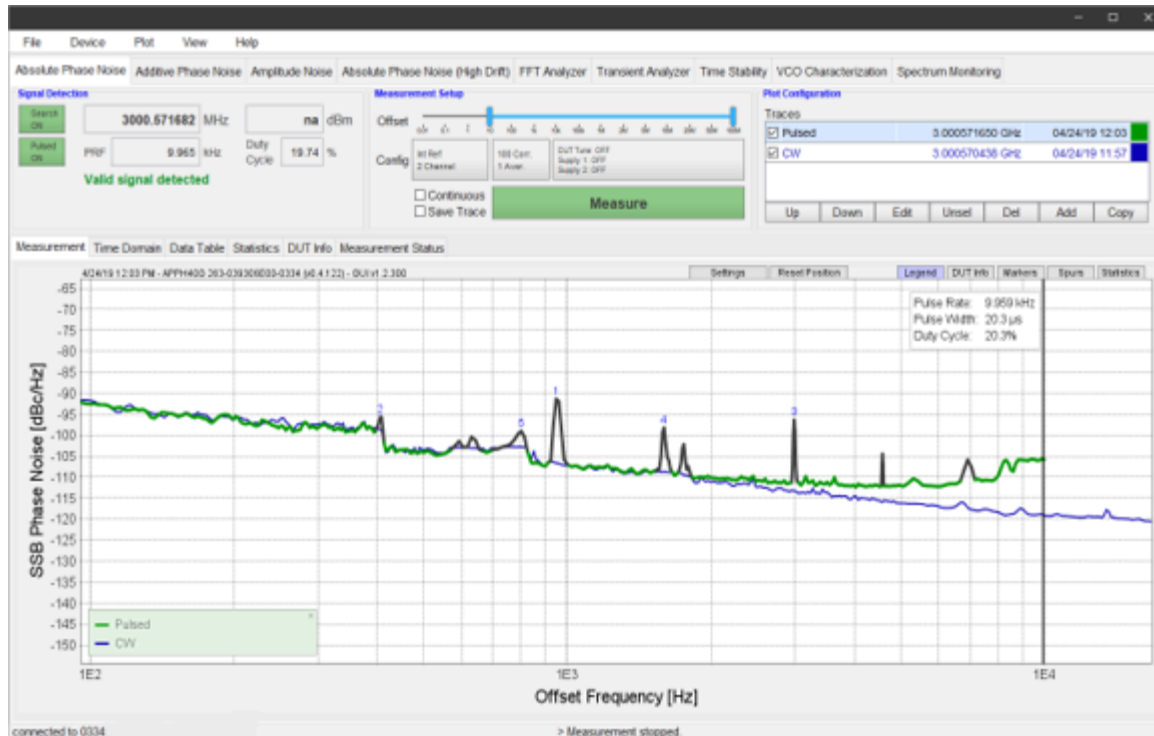

Description

PULSED Absolute and additive phase noise

- Detects pulses / pulse trains with a fast power detector
- Can lock to periodic pulsed signals and (aperiodic) pulse trains
- Automatic detection of duty cycle and pulse repetition frequency (PRF)

PULSED Amplitude noise

- Pulsed characteristic can be analyzed directly with I/Q demodulation
- Measured digitally

BURST mode

- Phase noise of individual pulses can be observed
- User selectable single pulse or pulse bursts (packet of pulses)

Performing Correct Phase and Amplitude Noise Measurements



Description

1. Reduce environmental influences

- High Use high quality, possibly short coaxial cables for RF and control/tuning signals and shielded wires for DC power supply
- Use precision DC power supplies or batteries to reduce influence from AC power grid (50 or 60 Hz) and from switching power supplies
- Minimize mechanical disturbances (vibrations, movement of setup during measurement, loud sounds)
- Reduce or shield from noise and interference sources (mobile phones, other DUTs, unrelated wiring/cords, computers)
- Shielding can help to reduce crosstalk, temperature variation, mechanical vibration

2. Use 7000 Series original AC power adapter

3. Setup in general

- Fixed setup so it can't move around
- Sufficiently warming up of 7000, DUTs and other components

4. External references

- Ideally use separate power supplies for each channel
- Physically separate references (to reduce channel-to-channel crosstalk)

Transient Analysis

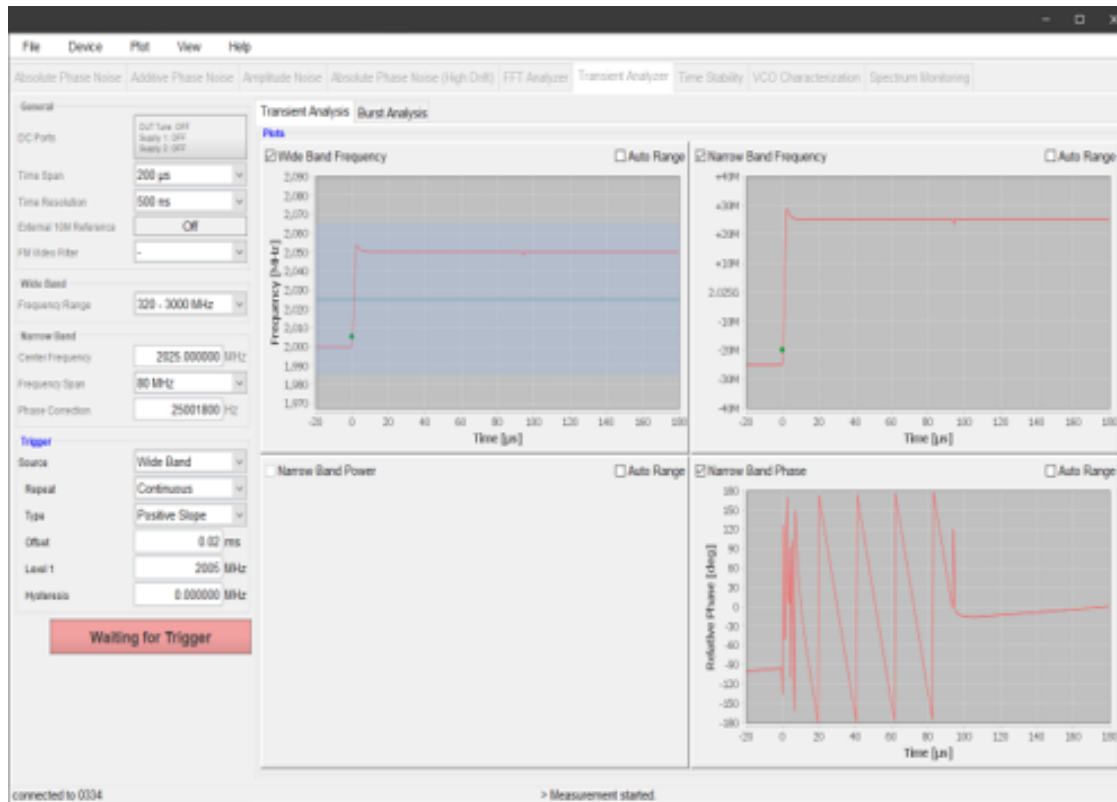

Description

- Look at short term behavior in time domain
- Wideband and narrowband mode (200 kHz up to 30 GHz span)
- Excellent time resolution (down to 8 ns)
- Frequency, Phase, Amplitude vs time
- Burst (time gating) mode phase noise
- Trigger mode can be set to internal (self-detecting), external (TRIG IN) or free running
- 4 display fields (max 3 pictures displayable)
 - Wide band freq vs time
 - Narrow band freq vs time
 - Amplitude/Power vs time
 - Phase vs. time or phase noise

VCO Characterization

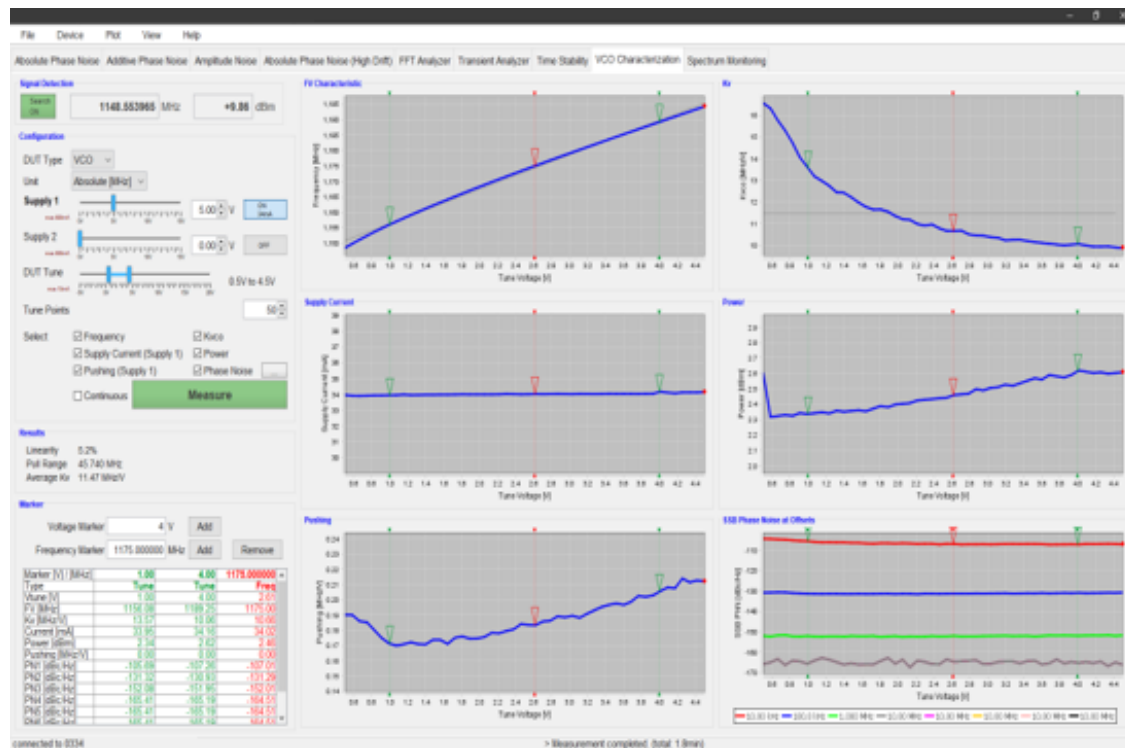

Description

- One-step, full characterization of both VCO- (wide frequency tuning range) and VCXO-style (narrow frequency tuning range) DUTs
- 6 display fields:
 - Freq vs. tuning voltage
 - Kvco vs tuning voltage
 - Supply current vs tuning voltage
 - Power and harmonics vs tuning voltage
 - Pushing vs tuning voltage
 - Phase noise vs. tuning voltage
- Can control various supply and tuning voltages in sweep mode (outputs available at front and rear)

Long-Time Frequency Stability Analysis

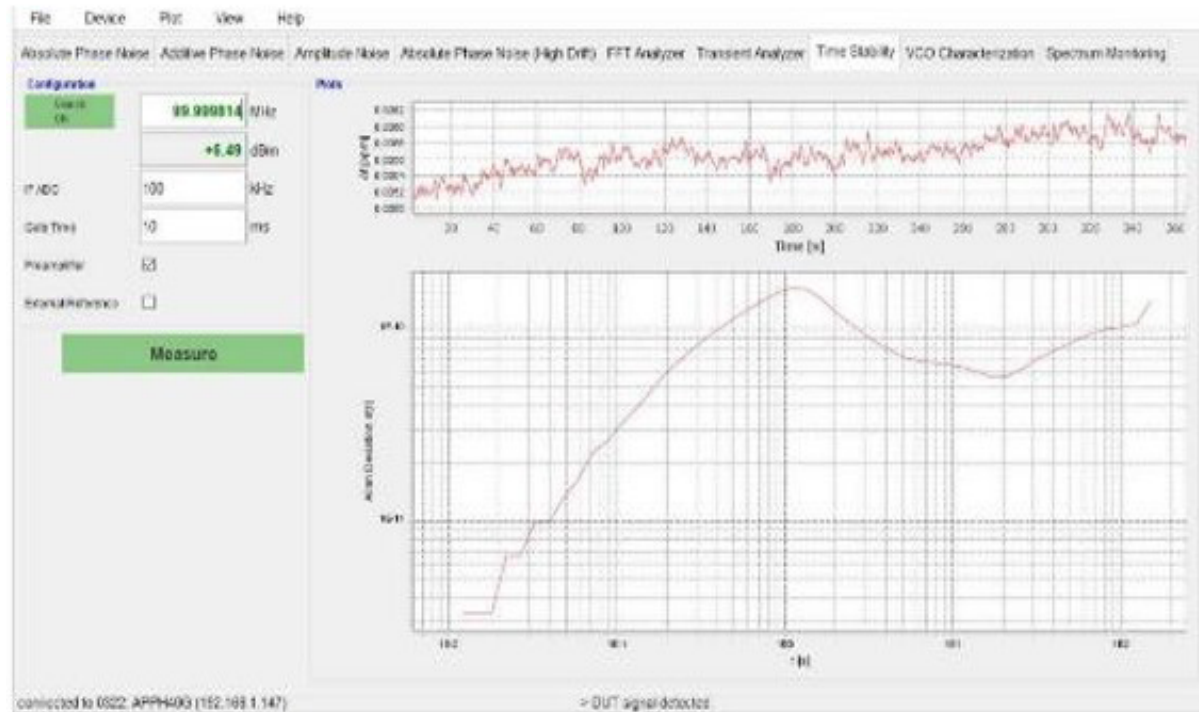

Description

- Testing time from 1 s to 10 days
- Frequency drift over time
- Allan Deviation (ADEV) over time

Spectral Analysis

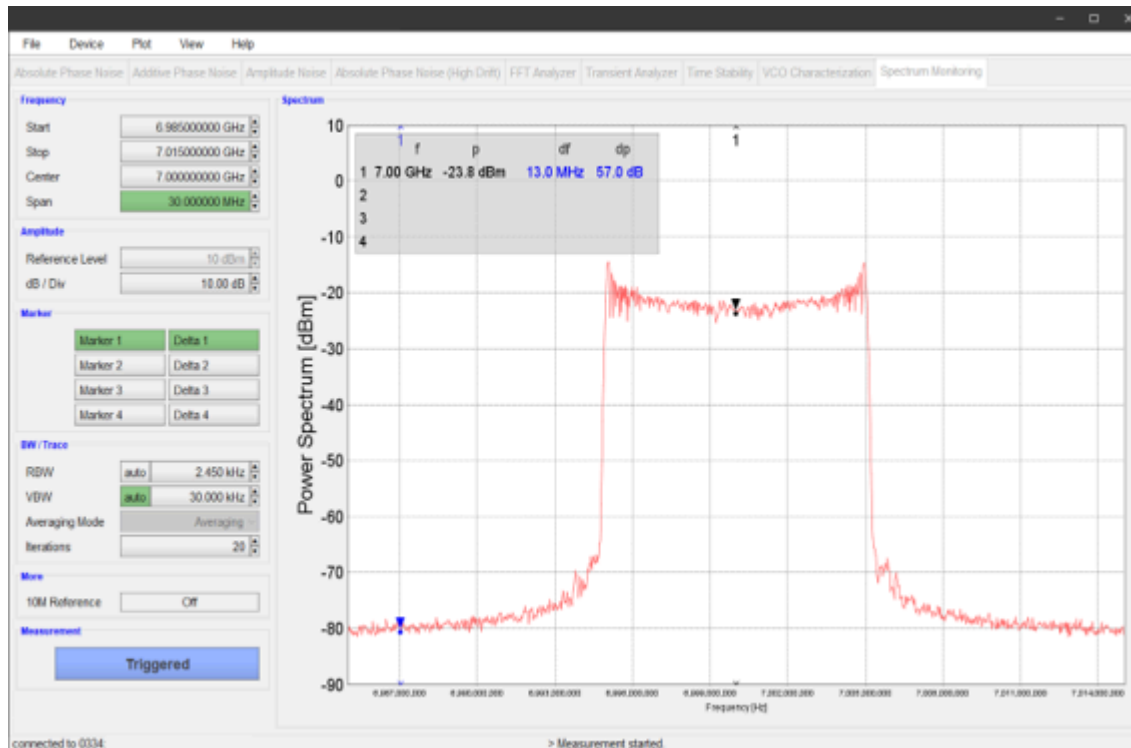

Description

- 5 MHz to 65 GHz
- Uncertainty: +/- 3 dB absolute; +/- 1 dB relative
- Noise floor: about -90 dBm/Hz

Traceable Calibration Procedure

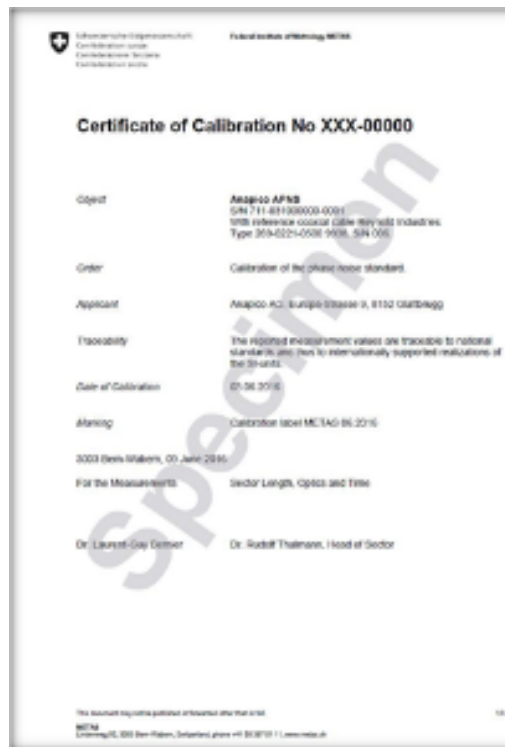

Description

- Traceable Phase & Amplitude Noise Standard to ± 0.5 dB, delivered with calibration certificate of accredited metrological testing lab.
- 7000 Series built-in calibration procedures
- Used at meteorological lab, or by 7000 Series end customer to quickly calibrate the phase and amplitude measurement correctness

Competitive Comparison



Parameters	BNC 7000			R&S FSWP		R&S FSPN
Frequency Range	1 MHz to 7/26/40/50/65 GHz			1 MHz to 8/26/50 GHz		1 MHz to 7/26.5 GHz
Offset Range	0.01 Hz to 100 MHz			0.01 Hz to 1000 MHz		1 uHz to 1 GHz
PhN Sensitivity dBc/Hz	Std	LN	EXT	B60	B61	
@100 MHz, 10 Hz offset	-105	-120	-130	-108	-117	-120
@100 MHz, 10 kHz offset	-175	-175	-178	-170	-170	-172
@1 GHz, 10 Hz offset	-85	-100	-110	-88	-97	-100
@1 GHz, 10 kHz offset	-155	-155	-170	-166	-166	-162
Measurement Modes						
PhN / AM noise / pulsed / pulse trains	Y/Y/Y/Y			Y/Y/Y/Y		Y/Y/N/N
Supporting ext. ref. for PhN testing	Y			N		N
Residual phase noise CW / pulsed	Y/Y			Y/Y		N
Burst Mode phase & amplitude noise	Y/Y			N/N		N
VCO Testing	Y			Y		Y
Transient Analyzer	Y			Y		Y
Time Stability (ADEV)	Y			Y		Y
Spectrum Analysis	Y			Y		N
Integrated Supplies / Tuning Voltage	Y/Y			Y/Y		Y/Y
Instrument Weight	10 kg			24 kg		> 20 kg
Power Consumption	70 W			300 W		> 200 W

Applications



Function	Application	Target Customer
Absolute Phase Noise / ATE	Automated (production) testing	Electronics manufacturers, semiconductor factories, design houses
Absolute Phase Noise	CW: Synthesizer, VCO, PLL, YIG, DRO, OCXO PULSED: Radar	R&D
Residual / Additive Phase Noise	Amplifier, transmitter, pre-scaler, phase coherence, synthesizer, phase stability	Active RF component manufacturer, semiconductor R&D, synthesizer R&D, accelerator time synchronization
Transient Analysis	Synthesizer switching, crystal startup behavior, modulation analysis, BURST mode phase noise analysis	Crystal manufacturer, synthesizer manufacturer
Time Stability	Device and module stability analysis	
VCO Testing	Characterization of VCO and other tuneable oscillating devices	VCO manufacturer
Spectrum Monitoring	Frequency drift, harmonics, modulations	

Spectrum Analyzers

Spectran V6

RTSA Suite Pro



Spectran V6

Ultra-Wide Frequency Coverage

Models up to 6 GHz, 7.2 GHz, 18 GHz, 40 GHz

True Real-Time Analysis

- Up to 160 MHz real-time bandwidth
- Gapless spectrum capture
- Zero signal loss during monitoring

High Dynamic Range & Sensitivity

- 16-bit ADC architecture
- Exceptional signal clarity in dense RF environments

Compact & Field-Ready

- USB-powered, lightweight design
- Ideal for lab, field, and mobile applications



Spectran V6

Ultra-Wide Frequency Coverage



Advanced I/Q Streaming

- Continuous I/Q data streaming
- High-speed data transfer for deep analysis

Dual Receiver Architecture

- Parallel signal monitoring
- Simultaneous measurement capability

Applications

- Spectrum monitoring
- EMC testing
- Interference hunting
- Wireless & 5G analysis
- Defense & aerospace testing

RTSA Suite Pro



True Gapless Real-Time Display

- 2D & 3D spectrum views
- Waterfall, persistence & histogram displays
- Constellation & modulation analysis

Unlimited Recording & Playback

- Continuous I/Q data recording
- Smart buffering & replay functionality

Advanced Trigger & Analysis Tools

- Real-time signal triggering
- Deep FFT analysis
- MATLAB & API integration ready



RTSA Suite Pro

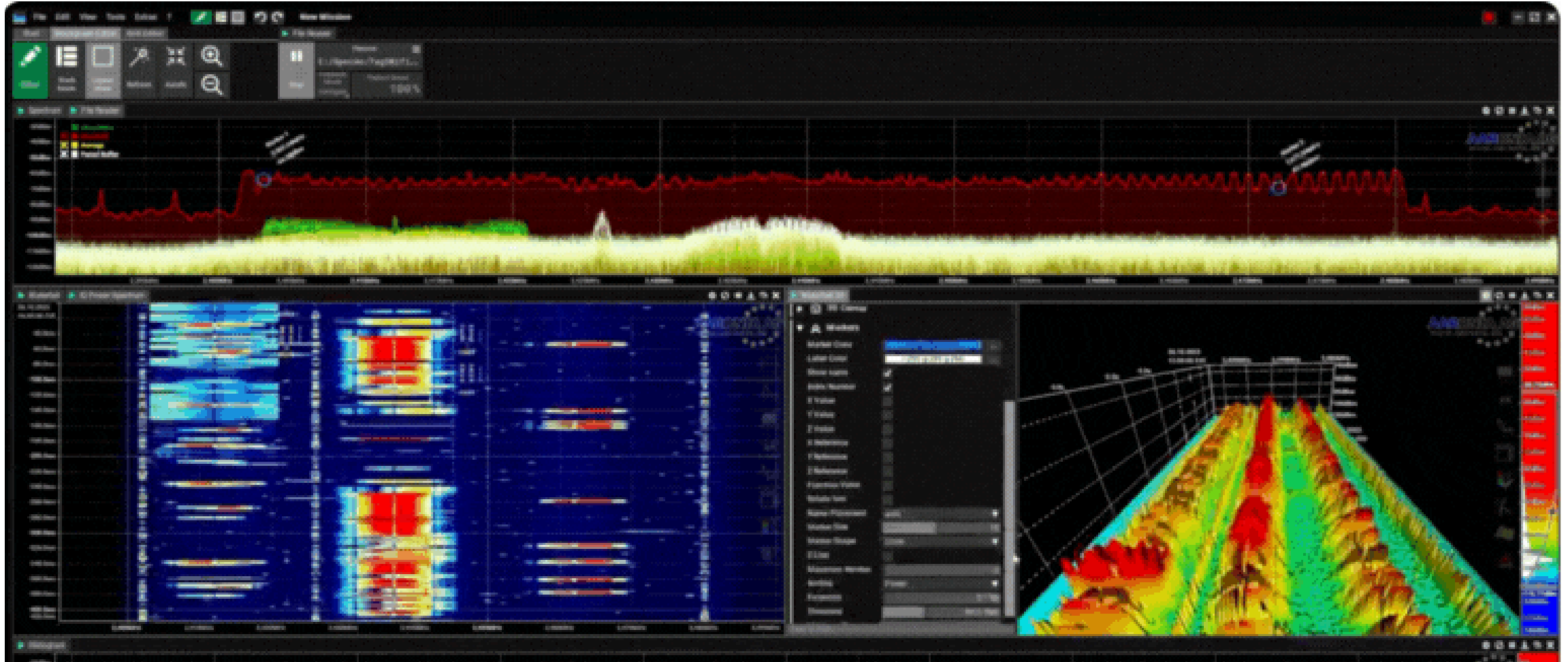

Contact Berkeley Nucleonics

Berkeley Nucleonics Corp.
2955 Kerner Blvd.
San Rafael, CA 94901
USA

Ph. 415-453-9955
Email: info@berkeleynucleonics.com

